

# igo

PREMIUM BIKES

## OWNER MANUAL

ASPIRE CAMILLIEN CE

ASPIRE VENDOME CE

DISCOVERY ROSEMONT LE

DISCOVERY YORKVILLE LE

DISCOVERY ROSEMOUNT LS

DISCOVERY YORKVILLE LS

OUTLAND CABOT RS

OUTLAND SAWBACK RS

OUTLAND TORNGAT RS

THE ROYAL UF

# RIDE THIS WAY

# CONGRATULATIONS

## YOU ARE THE PROUD NEW OWNER OF AN iGO eBIKE

We have taken great care to create an incredible product and hope you enjoy riding it as much as we enjoyed creating it. We encourage you to take the time to familiarize yourself with all the functions and capabilities that are now available to you – please read this comprehensive guide carefully before riding your new eBike. Whether you ride to commute, to go shopping or just ride for riding's sake, you will do so in comfort and confidence on your new iGO electric bike.

If you want to know more about your electric bike or discover tips and hints to get the most out of any ride, consult the ever expanding wealth of knowledge available at :

[assist.igoelectric.com](http://assist.igoelectric.com)

We wish you many happy rides with your new electric bike.

## FRAME SERIAL NUMBER

The serial number is located on the frame on a label on the underside of the down tube or non-drive side chainstay (close to the bottom bracket)

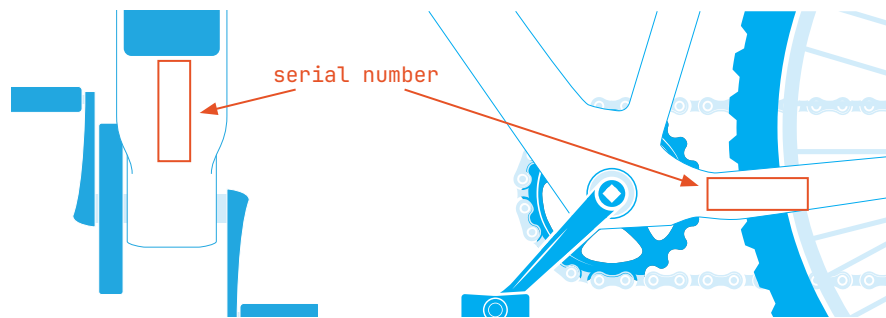

My serial number is :

— — — — —

My key number is : \_\_ \_\_ \_\_ \_\_

*(key number can be found on a metal tag attached with the keyring)*

Your electric bike may differ from the illustrations in this manual.

iGO highly recommends having your new eBike assembled and adjusted by a professional bicycle technician.

Note:

iGO Electric reserves the right to make changes without notice to design(s) and / prices listed in this manual.

This manual has been compiled with great care. iGO cannot be held responsible for any inaccuracies.

## IDENTIFY YOUR iGO ELECTRIC BIKE

I am the proud owner of :

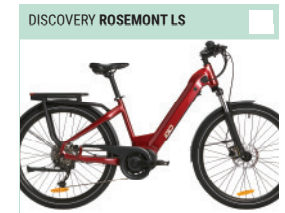

I bought this from :

(date) :

*I shall affectionately refer to my bike as :*

## REGISTER YOUR eBIKE

To gain full access to all owners benefits and warranty coverage register your bike at :

[register.igoelectric.com](http://register.igoelectric.com)

# TABLE OF CONTENTS

## 6 iGO DRIVE

- 6 About iGO Drive
- 6 Multi Class Switchable
- 7 Display And Functions
- 7 Operating The Display Unit
- 8 Parameter Settings
- 10 What Are Pedal Assistance And Assist Segments?
- 10 About Cadence Sensing
- 10 About Torque Sensing
- 11 About Walk Assist
- 11 Throttle
- 12 Removing The Throttle
- 13 Battery
- 13 Battery Sleep Mode
- 14 Identify The Battery (Discovery & Outland)
- 15 Remove / Install Battery (Discovery & Outland)
- 16 Identify The Battery (Aspire)
- 16 Remove / Install Battery (Aspire)
- 17 Identify The Battery (The Royal)
- 17 Remove / Install Battery (The Royal)
- 18 Charging The Battery
- 19 Battery Range And Capacity
- 20 Important Battery Safety Information
- 21 Electronics Access Port (EAP)
- 21 Weatherproof Connectors

## 22 iGO RIDE

- 22 About the iGO Ride mobile app
- 22 Download
- 22 Connecting Your iGO eBike To The Mobile App
- 23 Principal Rider : Pairing And Sharing
- 23 iGO Ride Home Screen Layout
- 24 Connect/Select eBike
- 24 Map
- 24 Trip History
- 25 Quick Actions
- 26 Personal Options Menu
- 27 eBike Options Menu

## 28 MECHANICAL COMPONENTS

- 28 The Groupset
- 28 About Gears And Shifting
- 29 Shimano Trigger Shifters
- 30 Microshift Drop Bar Levers
- 32 Disc Brake Alignment
- 32 How To Bed In New Disc Brake Pads
- 33 Adjusting Mechanical Disc Brakes Or Cable Actuated Hydraulic Brakes
- 33 Adjusting Hydraulic Disc Brakes
- 34 Adjustability And iGO Ergofit
- 34 Adjusting The Seat Height
- 34 Adjusting The Saddle Position
- 35 Adjusting The Handlebars (Quick Release)
- 35 Installing The Handlebars (4 Bolt Stem)
- 36 Rear Wheel Removal And Installation
- 36 Tire Pressure
- 37 Adjusting The Suspension Fork
- 37 Quick Release, Q-Loc, And Thru Axle Fork

## 40 FOLDING FRAME

- 40 Folding / Unfolding
- 41 Adjusting The Handlebar Position (Folding Stem)
- 41 Stem safety Catch
- 41 Frame Safety Catch

## 42 iGO ASSIST

- 42 What Is iGO Assist?
- 42 How To Access iGO Assist
- 43 Diagnostics And Warning Codes
- Main Technical Parameters, Specifications, And Parts :
- 44 Discovery Rosemont LE
- 45 Discovery Yorkville LE
- 46 Discovery Rosemont LS
- 47 Discovery Yorkville LS
- 48 Outland Cabot RS
- 49 Outland Sawback RS
- 50 Outland Torngat RS
- 51 The Royal UF
- 52 Aspire Camillien CE
- 53 Aspire Vendome CE
- 54 Torque Table
- 55 Servicing
- 55 Cleaning
- 56 Important Safety Instructions

## 58 WARRANTY

- 58 Warranty Limitations
- 59 Warranty Terms

## 63 REGISTER YOUR eBIKE

For assistance setting up your new iGO eBike, a full assembly instruction video is available at :

[www.igoelectric.com/getStarted](http://www.igoelectric.com/getStarted)

## ABOUT iGO DRIVE

Each iGO Drive system has been developed and custom configured for optimal performance within the defined parameters of each eBike. The systems are :

**CE DRIVE :** Light weight and efficient power transfer to deliver instant top-up assistance to the rider. Incorporates a dual side 40 pulse electronic torque sensor with a discreet slim form rear hub drive. 250W | 36V | up to 45Nm torque.  
Drive systems are custom configured for each application (all-road tuned/city tuned).

**LE DRIVE :** Smooth, simple, dependable for consistent and effortless control. 32 pulse electronic cadence sensor. Geared rear hub motor. 500W | 48V | up to 55Nm torque.  
Drive system custom configured for leisure focused riding.

**LS DRIVE :** Intuitive natural ride experience for energetic active transport. Dynamic mid motor system with torque, cadence, and speed sensor. 350W | 48V | up to 100Nm torque. Drive system features city tuned configuration.

**RS DRIVE :** Powerful, exciting, and sport performance delivering a natural ride experience on or off road. High output dynamic mid motor system with torque, cadence, and speed sensor. 500W | 48V | up to 130Nm torque.  
Drive systems are custom configured for each application (all-road tuned/cross-country tuned).

**UF DRIVE :** Robust and empowering. Fatbike specific rear hub motor with increased torque. 32 pulse electronic cadence sensor. 500W | 48V | up to 80Nm torque.

Each utilizes an advanced electric system that works in conjunction with the smart Battery Management System (smart BMS) found on iGO premium eBikes to offer increased efficiency in performance, detailed system information, and increased safety when in use or during storage. Connection to the peripheral components is by quick secure weatherproof connectors, allowing for simple maintenance and customization. The primary control unit and cyclocomputer interface is attached to the eBike handlebar while the Bluetooth technology in premium iGO eBikes allows interaction with your mobile device – through the iGO RIDE mobile app – for advanced ride controls, personalization, diagnostic information, ride mapping and social interaction.

## MULTI CLASS SWITCHABLE

These iGO Drive systems are programmed to be ‘multi class switchable’ allowing parameters to be instantly reconfigured at the touch of a button to conform to Class 1, 2, or 3 regulations. See page 25 to switch class using the iGO Ride mobile app RIDING MODE function.



Throttle thumb controls on iGO eBikes function when in Class 2 and 3, and are fully disabled in Class 1. The throttle can easily be removed from the eBike when not required.

## DISPLAY AND FUNCTIONS

The battery must be installed in the electric bike for the display to function. Make sure that the battery is securely locked into the bike prior to riding. It is recommended to remove and securely store the key when you are riding your electric bike.

The display unit houses controls for the electric systems of the iGO eBikes and is also the cyclocomputer interface.

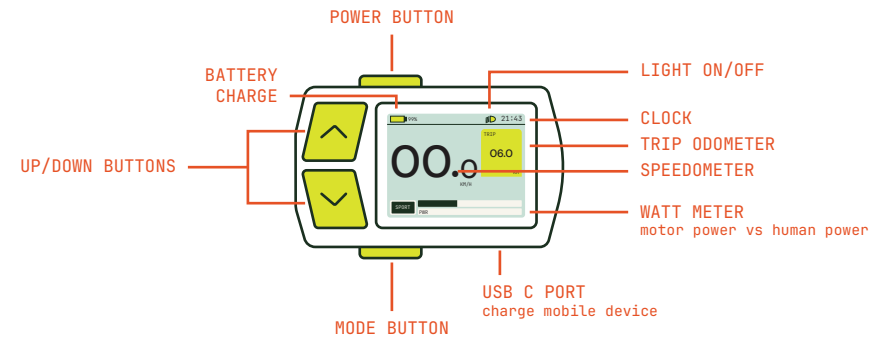

## OPERATING THE DISPLAY UNIT

### Power on/off

Turn the power on or off by pressing and holding the POWER button on the top of the unit for 2 seconds. The display will turn off after a pre-determined period of inactivity to conserve energy. The time duration can be changed (see section ‘parameter settings’).

### Change assist segments

Short press the UP/DOWN arrows to switch between assistance segments (off/eco/tour/sport/turbo/boost). When power is turned on, your iGO eBike will start with the assist ‘off’ as a safety precaution. In this state no power is provided to the throttle or to the pedal assist.

### Lights and display backlight on/off

To turn the display backlight (and any installed headlight/rear light) on or off press & hold the UP arrow for 2 seconds.

### Walk assist

Press & hold the DOWN arrow for 2 seconds to engage walk assist. Release the DOWN arrow to disengage walk assist.

Note : If a diagnostic (warning/error) code appears on the eBike’s display unit, check the table on page 43 and take the appropriate action.

### Advanced information menus

Short press the MODE button to toggle through advanced information display on the screen :



- Trip time
- Average speed
- Max. speed
- Odometer

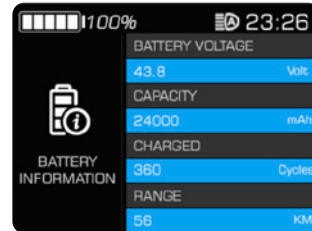

- Battery voltage
- Battery capacity
- Total charge cycles
- Remaining range estimate

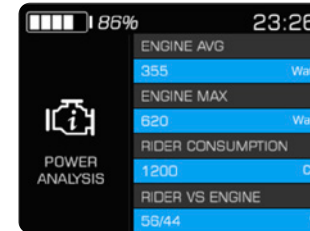

- Average motor power (Watts)
- Max. motor power (Watts)
- Rider exercise (Calories)
- Rider vs Motor (%)

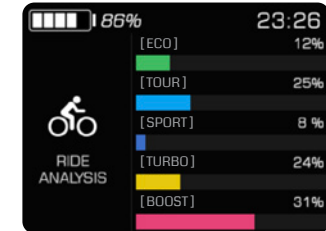

Comparative analysis showing percentage use of assist power segments.

### Settings menus

Press and hold MODE button within 10 seconds of turning on display to access the parameter settings menus.

## PARAMETER SETTINGS

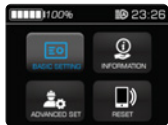

Use the UP and Down arrows to move between options. Short press the MODE button to select or long press the MODE button to go back.

Note:

The menu will automatically quit after 30 second of inactivity.  
The menu will automatically quit when you start riding.  
For safety reasons you cannot change settings while riding.



#### Basic settings

Unit : set to km/h or MPH  
Set time : Adjust displayed time (clock)  
Maintenance : set distance traveled until the service reminder is shown  
Backlight : set screen brightness  
Autosleep : set period of inactivity until screen turns off  
Password : enable\* (then enter a 4 digit code) or disable

\*when enabled, the selected 4 digit code will be required every time the display unit is powered on, before the eBike electrical system can become operational. A password prompt will show at start up. The correct code must be entered to access the electrical system controls and cyclocomputer interface.

PLEASE TAKE CARE TO REMEMBER YOUR PASSWORD AND ENSURE THE PASSWORD IS KEPT SAFE



#### Information

Providing detailed information for the display, battery and controller.  
The installed firmware version (for display, battery and controller) can be viewed within this menu.



#### Advanced settings

Settings in this menu are locked as they effect the performance, function, and safety of the eBike and are intended to only be monitored or reset by authorized iGO service representatives. Should you believe settings in this menu require attention contact iGO support.



#### Reset

Select 'yes' to reset the eBike's bluetooth connections.  
Any previous link to an iGO Ride mobile app account will be abandoned and the eBike will become detectable by other iGO Ride mobile app users.

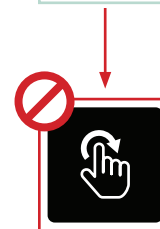

#### CAUTION.

If the 'reset' icon shows a hand icon (see left) your display requires updating to a more recent firmware version.  
**Selecting 'yes' in the reset setting when running outdated firmware will fully reset the eBike to factory settings and may require reprogramming in order to re-enable certain functions.**

If you see the hand icon update the firmware immediately through the iGO Ride mobile app before proceeding to use your eBike.  
(see page 27 for instructions how to check and install updates using the iGO Ride mobile app)

## WHAT ARE PEDAL ASSISTANCE AND ASSIST SEGMENTS?

Pedal assistance is the way an electric bicycle enhances – or magnifies – the effort exerted by the rider on each pedal stroke. This will allow the rider to travel further or faster while exerting the same effort, or simply enjoy a more relaxed ride while using less energy and effort.

5 specific assistance segments have been created for the iGO premium eBikes, each intended to be beneficial in differing circumstances. Each segment is color coded for easy recognition while riding. The intensity of pedal assistance provided by the eBike is determined by the assist segment selected.

<b>ECO</b>	Moderate assistance for conserving battery power
<b>TOUR</b>	Optimal assistance for longer rides
<b>SPORT</b>	Powerful assistance for challenging terrain
<b>TURBO</b>	Extra burst of power for quick acceleration
<b>BOOST</b>	Maximum assistance for climbing steep hills

The assistance can also be set to 'off'. This will disengage all assistance when pedaling, allowing the bike to be ridden as a standard non electric bicycle. The lights, cyclocomputer functions, and connection with the iGO Ride Mobile App will continue to function but the motion of the bicycle will rely solely on the riders manual effort. (For your safety iGO electric bicycles default to assist 'off' each time the bike is powered on for safe mounting and dismounting.)

Note : the throttle will also be inactive when assistance is set to 'off'.

Be aware that the motor will draw more power from the battery as more assistance is used. Extending the range of the battery can be achieved by reducing the intensity of assist used. Understanding the efficient use of bikes gears to complement pedal assist levels will allow for a smoother riding experience, can extend the range of the battery and has an added benefit of exerting less stress on bike components allowing them to last longer before requiring replacement.

Assistance will engage in different ways depending on the type of sensor being used.

## ABOUT CADENCE SENSING

Pedal assist with cadence sensor allows the rider to have assistance as soon as the rider begins to pedal and for as long as the rider continues to pedal. The iGO cadence sensor is located in the bottom bracket, weather-proof and away from potential harm or tampering. It uses up to 32 optic sensor points to let the system know when the rider has started or stopped pedaling making it extremely efficient and fluid in the system's ability to deliver assistance.

## ABOUT TORQUE SENSING

Pedal assist with a torque sensor enables the system to provide measured assistance based on the rider's effort. The sensor uses pressure and strain gauges to measure the effort that the rider is putting into the pedals and provides the required assistance to ensure a smooth and comfortable balance. The more effort the rider puts into the pedals, the more the system assists.

## ABOUT WALK ASSIST

USE CAUTION WHEN ENGAGING THIS FEATURE AND ENSURE THAT YOU ARE IN CONTROL OF THE BICYCLE BEFORE OPERATING WALK MODE

Walk Assist mode enables the bike to "walk" beside the rider at 6km/h. This feature is practical for walking the bike up-hill, when guiding on to a bike rack or carrier as well as when advancing with the bike over any surface that may be difficult to pull/push the bike through (mud, snow, sand, etc).

Release the DOWN arrow to disengage walk assist at any time. As a further safety measure pulling on either brake lever will trigger the power-cut off switch which will disengage power and walk assist.

## THROTTLE

Throttle thumb controls on iGO eBikes function when in Class 2 and 3, and are fully disabled in Class 1. Pushing down on the throttle will provide an immediate boost of acceleration to the bike (whether pedaling or not). The bicycle will continue to accelerate until the throttle is released or when the bicycle reaches its maximum assist speed limit. If the throttle is held down while at maximum assist speed the bicycle will continue to cruise and maintain speed limited power, but no additional acceleration will occur in assisted pedaling until the speed drops below the limit.

For rider safety the throttle is inactive when assistance is set to 'off'.

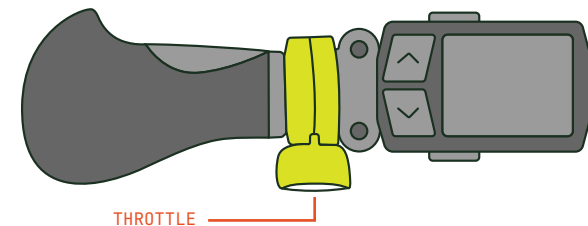

Note : Sudden bursts of acceleration – especially from a stationary position – can exert extra stress on components. Selecting the correct gear and pedaling to build up momentum before engaging the throttle to accelerate will extend the life of your bicycle components.

## REMOVING THE THROTTLE

The throttle can easily be removed from the eBike if required for Class 1 riding by following these steps :

Locate the throttle weatherproof twist connector (orange connection). Unscrew the twist connect and gently pull to disconnect the throttle cable.

Loosen the securing bolt located under the throttle using a 3mm Allen key. (Loosen the bolt enough to be able to freely manipulate the throttle but not so much that the bolt falls out of the housing).

The handlebar grip will need to be removed in order to slide the throttle assembly off the end of the handlebar. Ensure that the grip is reinstalled securely as an important safety precaution.

To re-install the throttle, repeat these steps in reverse while taking care to properly line up the pins in the connection before applying any pressure.

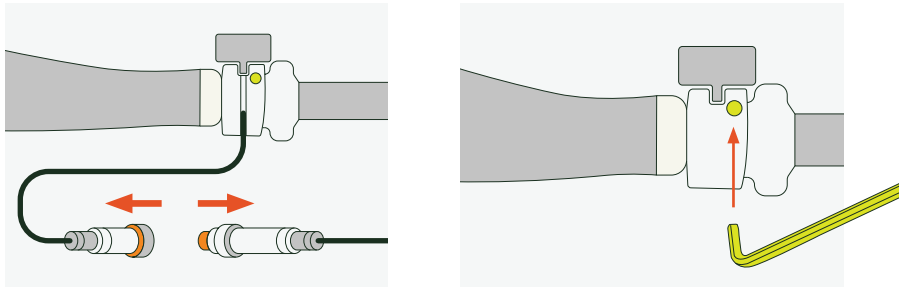

## BATTERY

All iGO batteries are secured to the bike frame using a barrel lock mechanism. The battery can be removed from the frame for charging, storage, or when leaving the bike in a public area by using the keys provided with the bike. Keys should always be removed from the bike before riding. **KEEP YOUR KEYS IN A SAFE PLACE.**

It is advisable to keep a note of your key number with this manual for future reference. The key number can be found on a metal tag attached with the keyring.

The iGO premium eBikes batteries utilize a smart Battery Management System (BMS). This advanced technology provides increased safety features, additional diagnostic information, statistical usage analysis, and greatly simplifies maintenance/care procedures. Diagnostics and battery analysis information can be accessed through the display unit and when using the iGO Ride mobile app. Safety and maintenance features are automatic and require no setup from the user.

## BATTERY SLEEP MODE

This automatic battery protection feature provides increased safety during storage and simplifies battery care to optimize performance while maximizing and even extending battery lifespan.

When the eBike has not been used for an extended period of time the battery will automatically enter a sleep state preserving and protecting the battery cells.

**The eBike electrical system will appear to be unresponsive when the battery is in the dormant state. This is normal.**

The table below indicates the combination of events that will trigger the battery to enter the sleep state.

When charge level is :	Battery will enter dormant (sleep) state after :
80% or more	-
40% - 79%	30 days
10% - 39%	14 days
1% - 9%	48 hours
less than 1%	10 mins

### To wake the battery :

Remove battery from the eBike and plug directly into the provided charger for approximately 30 seconds. Locate and press the power meter button for 3-5 seconds until the power indicator LED lights up. This indicates the battery has been reactivated and can be replaced into the eBike for immediate use.

## IDENTIFY THE BATTERY (DISCOVERY & OUTLAND)

The battery for the Discovery and Outland eBikes has the following features :

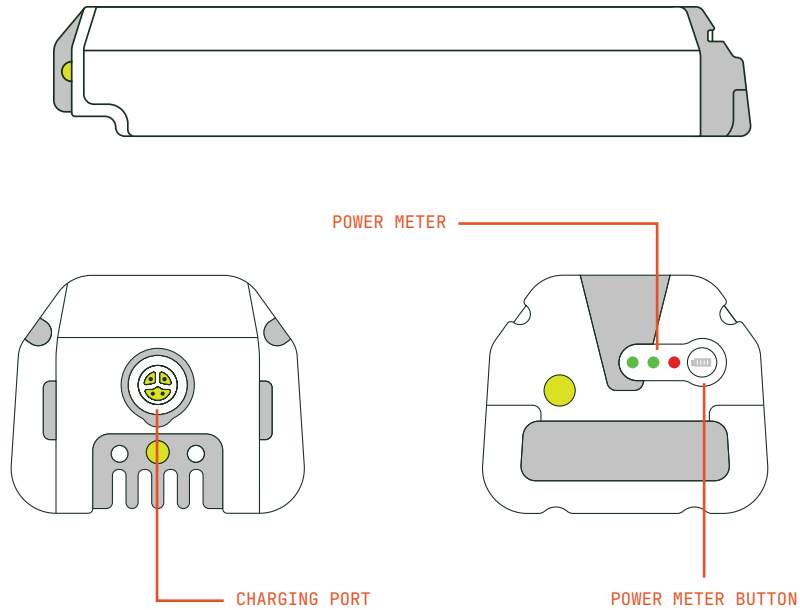

### On frame battery charging port

The frame charging port is located on the top left side of the down tube (non-drive side). Lift the charger port cover to gain access to the port to charge the battery when it is installed in the bike.

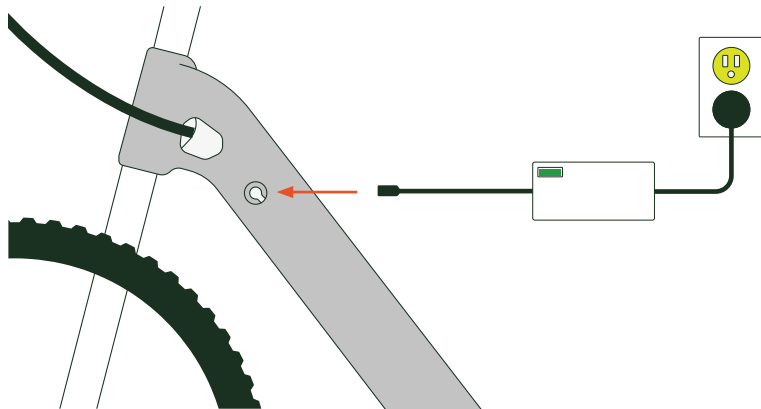

## REMOVE / INSTALL BATTERY

To remove the battery from the bike frame first remove the battery cover under the battery tube by pushing down on the top latch and tipping the top edge down on an angle, then lift and remove.

Insert the key into the lock but do not turn at this time. Support the battery with one hand & use the other to turn the key 90° clockwise to the unlock position. While holding the battery parallel to the frame carefully allow the battery to drop out of the frame.

To reinstall the battery, insert the key into the battery lock but do not turn at this time. Hold battery parallel to frame and line up the battery with the receptacle. Insert the bottom portion of the battery first, and then with one hand turn the key 90° counter clockwise to the lock position. Push the top part of the battery into the receptacle until you hear the latch close onto the battery. At this point the battery will hold itself in place. With both hands on each side of the frame and thumbs under the battery case push the battery to make sure its locked and secure.

Reinstall the battery cover by inserting the tab on the bottom part of the battery cover into the slot located under the battery. Once inserted tilt the cover and latch into place.

Always lock battery & remove the key while riding.

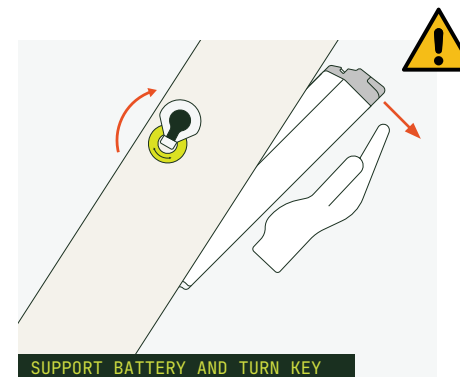
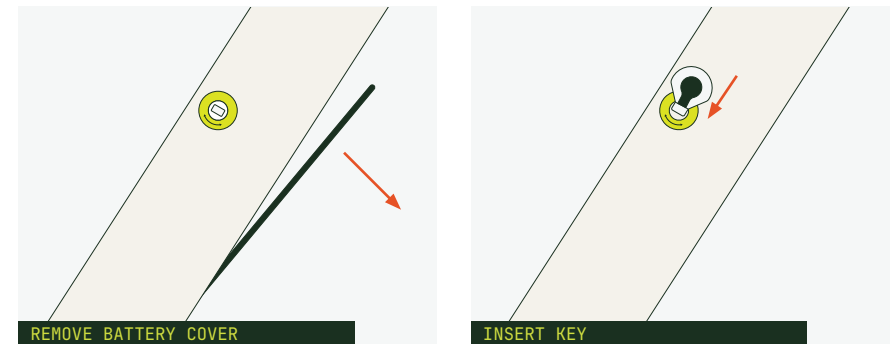

### CAUTION

When the key is turned the battery lock will be released. The battery must be supported to avoid falling from the frame.



## IDENTIFY THE BATTERY (ASPIRE)

The battery for the Aspire Camillien CE and Aspire Vendome CE has the following features :

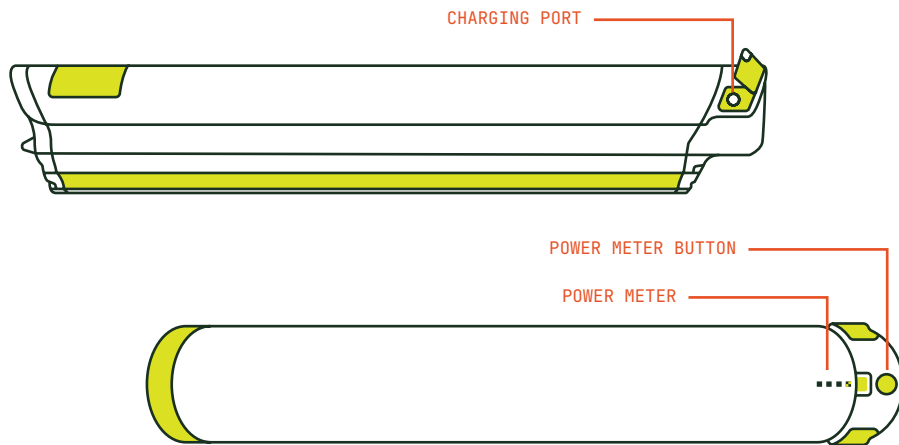

### Battery status

Press and hold the power meter button.

Blue	~ 100%
Green	~ 50%
Red	Needs Charging

## REMOVE / INSTALL BATTERY

To remove the battery from the bike frame, insert key & Turn 90° clockwise. The battery will release from the receptacle. Lift the battery from the top black edge on an angle as shown below.

To re install the battery first insert the lower part of the battery into the receptacle at the same angle as removal, then push the top of the battery into the receptacle. You will hear a click of the lock when the battery is secured onto the bike. Ensure the battery is secure by attempting to gently turn the key in the lock. When installed correctly there should be no 'give' (the key will not turn).

Always lock battery & remove the key while riding.

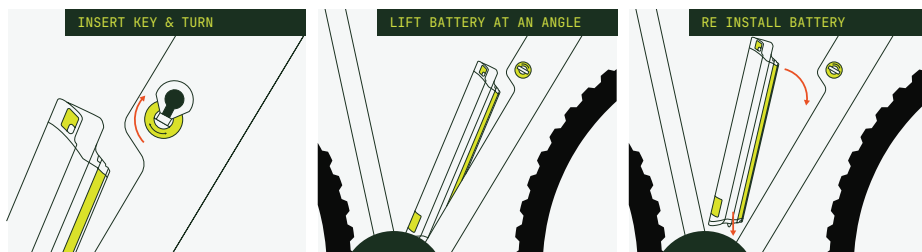

## IDENTIFY THE BATTERY (THE ROYAL)

The battery for The Royal UF has the following features :

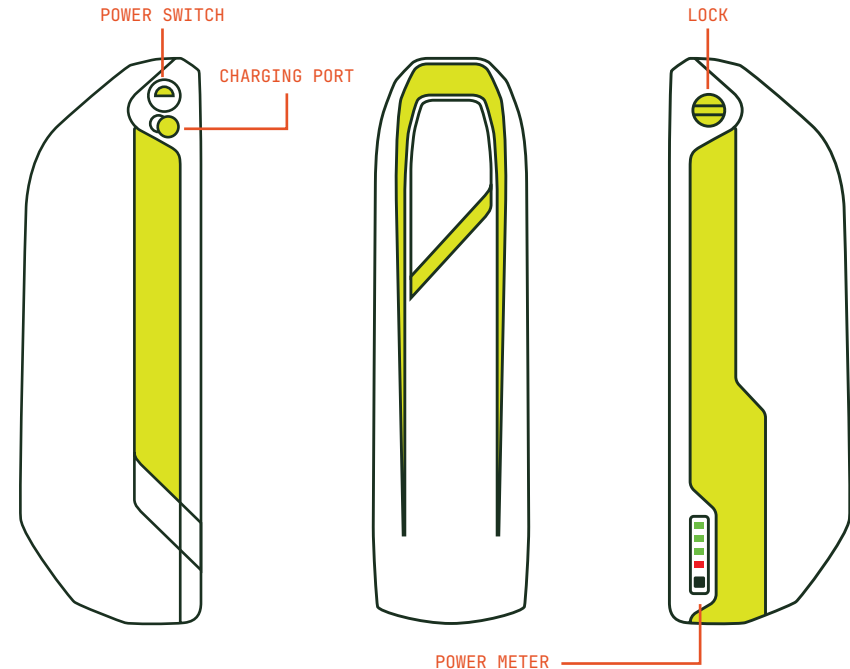

## REMOVE / INSTALL BATTERY

To remove the battery from the bike frame, insert key & Turn 90° clockwise to the unlock position. Lift the battery straight up by 2" and remove from the receptacle as shown below.

To re install, line up the battery to the receptacle as shown below and push down into position. Lock the battery by turning the key 90° counter clockwise.

Always lock battery & remove the key while riding.

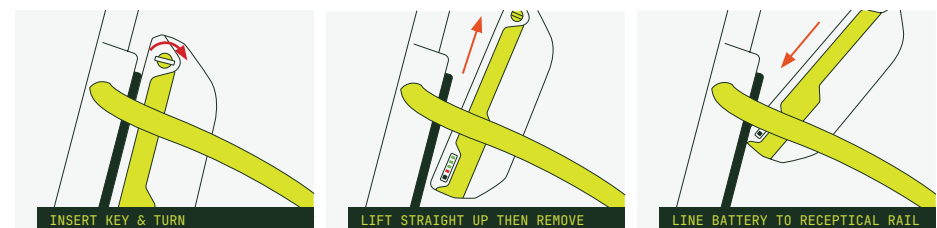

## CHARGING THE BATTERY

The battery can be charged both on and off of the bike.

It is important to follow these charging instructions in order :

1. Plug the charger's male plug into the battery/bike charging port.
2. Plug the charger into an approved 110 volt outlet.

### DO NOT USE A POWER EXTENSION CABLE

The indicator LED on the charger will light green for a few seconds and if a charge is necessary, the LED will turn red. The battery is fully charged when the battery indicator LED becomes green.

When charging is complete :

1. Unplug the charger from the outlet first.
2. Unplug the charger from the battery/bike.

### YOU MUST ALWAYS CHARGE YOUR BATTERY WITH THE SUPPLIED BATTERY CHARGER. FAILURE TO DO SO MAY RESULT IN FIRE, PERSONAL HARM, DAMAGE TO PROPERTY YOUR BATTERY OR eBIKE

When the battery has become completely depleted you must charge it immediately. If the cells are left depleted for a long period of time, they may become irreparably damaged. Make sure to only charge the battery in a dry, well ventilated area. Unplug the charger when the battery is fully charged, or when charger is not in use. Do not throw an expired battery in the trash. Please recycle your battery at an authorized recycling company in your area.

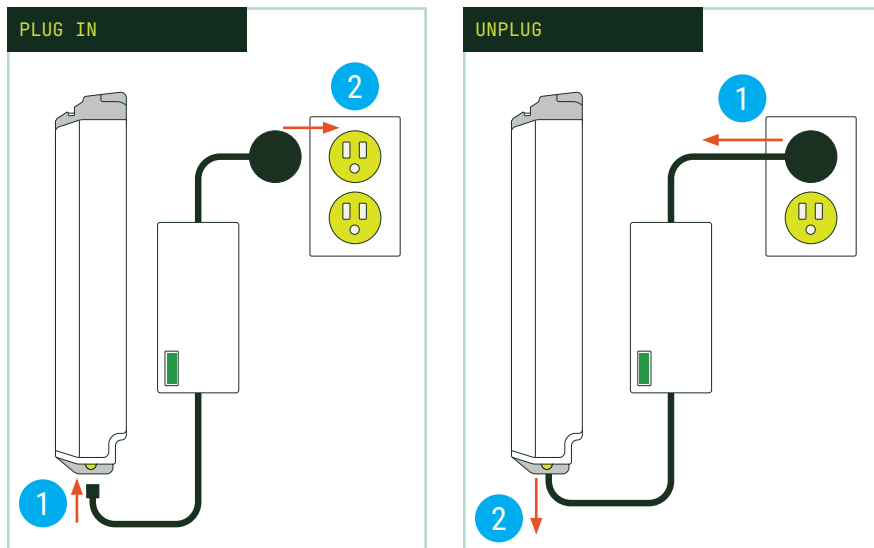

## BATTERY RANGE AND CAPACITY

### How far can I travel on my electric bike?

The total distance you can travel on your electric bike is not an easy amount to specify. The range depends on many different factors including, but not limited to :

- The level of pedal assistance and throttle usage
- Resistance (wind, tire pressure, speed, inclines, road conditions and altitude)
- Total Weight (weight of the bike + rider + cargo)
- Outside Temperature
- The condition of the battery (battery capacity decreases as the battery ages)

Batteries are often compared based on capacity (Amp hours - Ah). However, a comparison based on capacity alone does not properly depict a battery since the performance of a battery pack is also based on battery voltage (V). The best way to compare battery performance is by looking at the amount of energy that can be provided in watt-hours (Wh). Wh takes into account both the capacity of the battery, as well as the average voltage during discharge. Simply put, the higher the V/Ah, the higher Wh range.

Watt hours calculation : Battery voltage (V) x Amp hours (Ah) = Watt hours (Wh)

Every individual will have their own riding style and determine their own preference for how much assist to use and when to engage this. The attainable distances will likely be as varied and unique as the riders, even over the same terrain using the same bikes. iGO only supply bikes with batteries that we confidently believe will allow sufficient range to sustain an active riding schedule between charges.

Efficient use of the gears while riding will greatly benefit your riding experience and extend battery range.

### Tips to maximize eBike range

- Maintain your tire pressure in the recommended range as indicated on the tires.
- Minimize the use of throttle, especially hard acceleration from a standstill.
- Pedal while you are accelerating, especially from a stop.
- Slow down and enjoy the ride - higher speeds use a proportionately greater amount of battery power.
- Lower the total weight of the rider and bike - carrying around excess weight will use extra battery power.
- Frequent starts and stops require more energy than steady-state riding. We recommend always obeying traffic signals, but if you can avoid pulling over many times during a ride, you will be rewarded with a greater range.
- Use the correct gear. Shift gears so that your pedalling cadence is maintained in the 70-90rpm range.
- A well-maintained bike is more efficient and will give greater range. Correctly lubed chains, brakes that do not rub and well-maintained wheel bearings will run much smoother and save battery energy.



## IMPORTANT BATTERY SAFETY INFORMATION

DO NOT connect the positive terminal of the battery to the negative terminal.

DO NOT open your battery as it will void warranty.

The battery is sealed and therefore is rain resistant, however, DO NOT expose your battery to repeated, continuous or excessive water flow.

Prolonged exposure to UV rays, rain and the elements may damage the enclosure materials, store indoors when not in use.

Battery is not intended for use at elevations greater than 2000 m above sea level.

If you should encounter problems with your battery: remove the battery from the bike and consult your authorized iGO retailer or iGO Support.

The performance of the battery will decrease at low temperatures. Ideal operating temperature is approx.  $-10^{\circ}\text{C}$  to  $50^{\circ}\text{C}$ . The guideline is that the capacity will decrease by 1% at every  $1^{\circ}\text{C}$  of temperature drop.

DO NOT expose your battery to high temperatures ( $>50^{\circ}\text{C}$ ), e.g. limit prolonged storage in direct sunlight or in proximity to a direct heat source.

The battery is intended to be charged when the ambient temperature is between  $0^{\circ}\text{C}$  ( $32^{\circ}\text{F}$ ) and  $30^{\circ}\text{C}$  ( $86^{\circ}\text{F}$ ). Never charge the battery when ambient temperatures are outside this range.

Make sure to only charge the battery in a dry, well ventilated area.

The socket-outlet shall be installed near the equipment and shall be easily accessible.

Unplug the charger when the battery is fully charged, or when charger is not in use.

Use ONLY the supplied charger.

Under ideal conditions, the battery pack can be recharged approximately 750 times. The performance will slowly decrease over time and eventually will need to be replaced.

To maintain optimal performance of Lithium-ion batteries which need to be stored for a long time and not used, they should be kept in a state of 50%-60% charge. They should be recharged every 3 months and recharged every half a year. Storage should be at moderate humidity levels and between  $10^{\circ}\text{C}$ - $20^{\circ}\text{C}$ . Elevated temperatures will increase the permanent loss of capacity.

The battery should be recycled properly at the end of its life. Please recycle your battery at an authorized recycling company in your area.

for : DISCOVERY ROSEMONT LE | DISCOVERY YORKVILLE LE

## ELECTRONICS ACCESS PORT (EAP)

The Electronics Access Port gives easy access to the controller, wiring harness and sensor array for the bicycle. It is located at the bottom bracket of the bike on the non drive side.

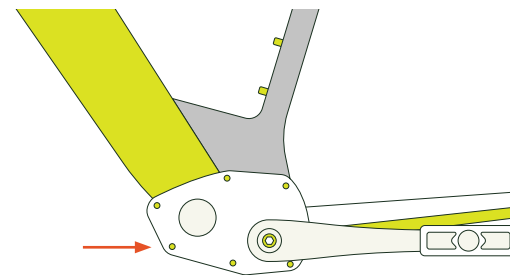

### To access the port :

1. Loosen the 6 securing bolts located around the Access Port cover using the correct sized Phillips head screwdriver.
2. Using a flat head screwdriver or other flat device, pry the cover off (ensuring that you go all the way around the edge of the cover as to not break any clamps or pins holding the cover in place).
3. Once the cover is loose, pull it towards you along the pedal shaft and let it swing down, revealing the controller and wiring harness.

To replace the cover, simply repeat the above steps in reverse, ensuring that you apply equal pressure around the cover to make sure it is completely flush before tightening the securing bolts.

## WEATHERPROOF CONNECTORS

Connection to the eBike peripheral components is by quick secure weatherproof connectors. These plugs make for a secure, dry and truly 'plug-and-play' set-up for simple maintenance and customization.

For simplicity the following colors are used to identify the cables connecting :

- red - Brakes
- orange - Throttle
- green - Display unit

When joining the weatherproof plugs take care to properly line up the pins in the connection before applying any pressure. Turn the two connectors together to fully secure.

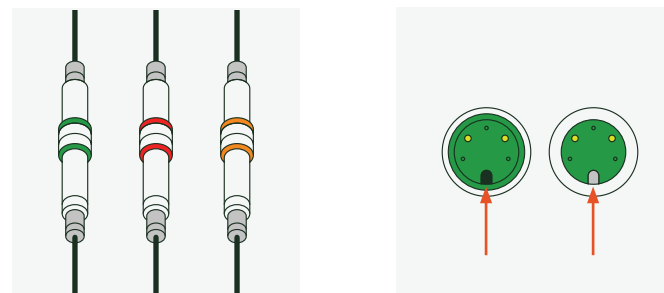

# iGO RIDE

FOR APP RELEASE VERSION 1.0.1



## ABOUT iGO RIDE

The iGO Ride mobile app provides advanced features and controls including instant multi-class switching, turn by turn navigation, advanced statistics, eBike security & power lock, social integration, battery range & health, servicing reminders, maintenance information. As the iGO Ride mobile app evolves and is further developed to offer the best possible riding experience some of the features detailed in the following pages may change over time. We advise checking the online development log at :

[www.igoelectric.com/igoride](http://www.igoelectric.com/igoride)

for further release notes and app development news

## DOWNLOAD

The iGO Ride mobile app is available on Apple's App Store for iOS devices and the Google Play Store for Android. Scan the QR code below for a quick link or search for 'iGO Ride' in the appropriate store for your device.



## CONNECTING YOUR iGO eBIKE TO THE MOBILE APP

1. Download and open the iGO Ride mobile app on your mobile device.
2. Create an iGO Ride account by following the on screen instructions.
3. Turn on your iGO eBike by pressing the POWER button on the top of the display unit.

The iGO Ride mobile app will automatically begin to scan for an iGO ebike. If successful an image/name of all ebikes within range will be shown on the screen. Tap on the image/name that matches your eBike and the iGO Ride mobile app will connect and associate the selected eBike to your iGO Ride account.

iGO eBikes can also be added manually by selecting the appropriate bike name/image from the bottom of the app scanning screen.

Additional iGO eBikes can be associated to your iGO Ride account by taping the CONNECT/SELECT eBIKE icon on the home screen then selecting the 'add equipment' option and scanning for bluetooth signal or manual selecting an eBike.

## PRINCIPAL RIDER : PAIRING AND SHARING

For a more secure experience each iGO eBike is designed to link with only one principal owner's iGO Ride account. Once linked, the bike will not be detectable by other iGO Ride mobile app users unless the principal rider shares access.

Sharing options can be found in the eBIKE OPTIONS MENU. Tap 'share device' and select the preferred sharing method from within the menu.

Or, to unpair the eBike and relinquish control, open the eBIKE OPTIONS MENU and select 'Remove Device' from the bottom of the screen. When removed from an account the eBike will be detectable by other iGO Ride mobile app users.

(iGO eBikes can also be unpaired from iGO Ride accounts by accessing the parameter settings on the handlebar display units. See page 9 for details).

## iGO RIDE HOME SCREEN LAYOUT

When one or more iGO eBikes are associated to your iGO Ride account you will have access to the home interface.

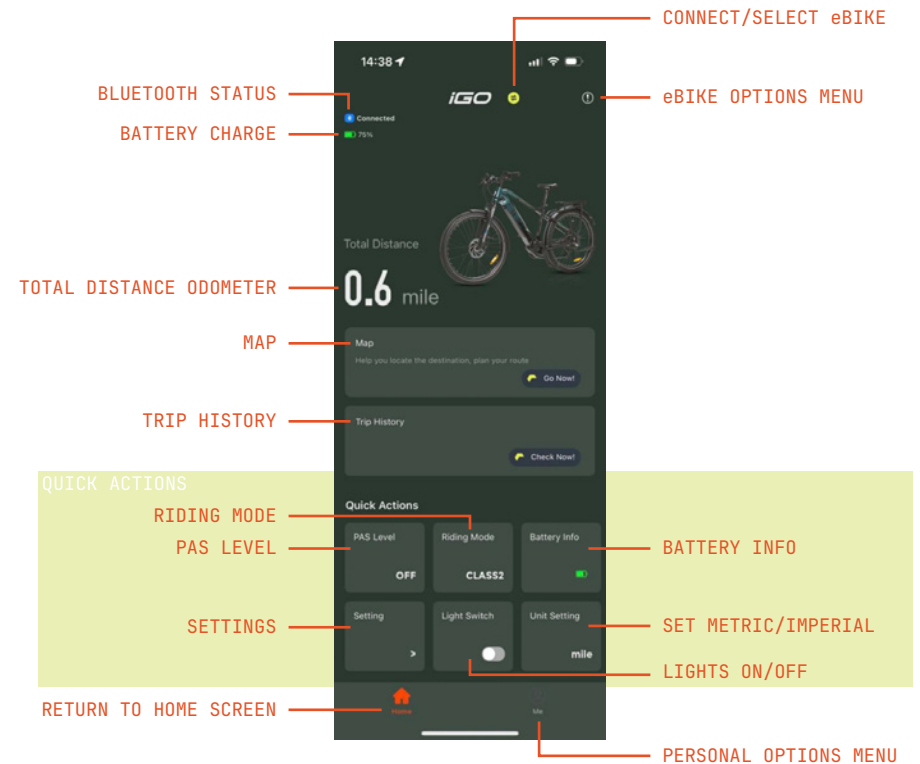

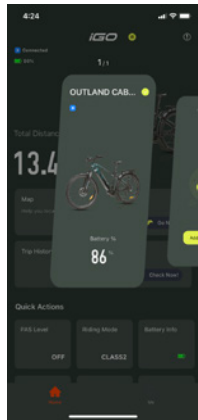

## CONNECT/SELECT eBIKE

From the home screen, use the CONNECT/SELECT eBIKE icon to scroll through all iGO eBikes currently associated to your iGO Ride account. Use the final tab to scan for (or manually identify) additional iGO eBikes.

Details and settings for the selected iGO eBike will be shown on the home screen and in the eBIKE OPTIONS MENU and TRIP HISTORY.

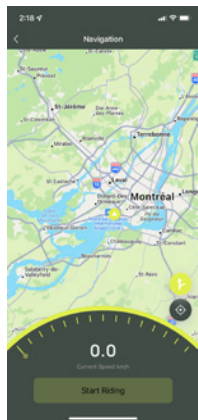

## MAP

The map function provides GPS and navigation functions to the iGO Ride mobile app. Turn by turn directions, ride tracking and the ability to share your rides on messaging apps and social media (location tracking must be active to use the GPS based functions of the map).

### Ride tracking

You can record your rides for viewing or messaging. Press START RIDING on the map page to begin recording a ride. To stop the ride recording feature press STOP RIDING.

Battery power and GPS signal strength are always in view while on the map screen. You will also see the ride in progress, Riding Time, Odometer, Average Speed, and Power in Watts.

## TRIP HISTORY

In trip history use CHECK NOW to enter the past rides list. Here you can view all of the rides recorded over a 30 day period. Select each to see the Riding Distance, Riding Time, Average speed, top speed, and Total Distance travelled to date.

You can share this information to any messaging email or texting software by using on the icon on the top right corner of any recored ride in the history log.

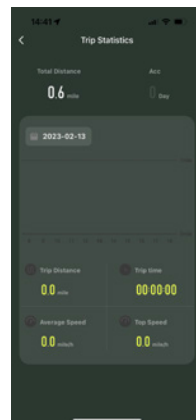

## QUICK ACTIONS *(see image on page 23 for reference)*

The lower part of the home screen provides large quick action buttons for common tasks :

### PAS level \*

Change the pedal assist segment (see page 10 for full pedal assist segment details).

### Riding mode

iGO premium eBikes are MULTI CLASS SWITCHABLE through the iGO Ride mobile app. Select from the list to reset the bike parameters and the selected iGO eBike will instantly conform to Class 1, Class 2, or Class 3 regulations.

Class 1 : No throttle function, PAS with maximum speed 32km/h (20mph)

Class 2 : Throttle and PAS maximum speed 32km/h (20mph)

Class 3 : Throttle maximum speed 32km/h (20mph), PAS maximum speed 45km/h (28mph)

**To engage class 3 the rider can only operate where permitted by local regulations and accept the liabilities and responsibilities of riding in this class.**

**ATTENTION :** Riding an ebike in class 3 in an area prohibited by law is a punishable offence. It is the riders responsibility to familiarize themselves regarding these regulations and further agrees to hold iGO/Fermetco harmless or responsible in any way in the operation of their ebike.

### Lights on/off \*

Turn on/off any front and rear lights that are directly connected to the iGO Drive system.

### Battery info

View current riding and health conditions of the selected iGO ebike's battery.

### Set metric/imperial

Choose to display speed and distance in Km or Miles.

### Settings

Password : enter and then confirm a 4 digit code. Once set, this will be required every time the display unit on the handlebar is powered on before the eBike electrical system will become operational. Swipe to the left on an active password to access the DELETE button.

Note : as bluetooth functions on the iGO eBike will not be enabled until the password is correctly entered, deleting the password using the iGO Ride mobile app will not be possible until a correct password has been entered on the handlebar display unit.

Passwords can also be enabled/disabled using the handlebar display unit. See page 8 for details.

PLEASE TAKE CARE TO REMEMBER YOUR PASSWORD AND ENSURE THE PASSWORD IS KEPT SAFE

\* these settings can also be changed using the handlebar display unit. See page 7 for details.

## PERSONAL OPTIONS MENU

Access this menu to view and edit your account details, see messages & alerts, and access FAQ content.

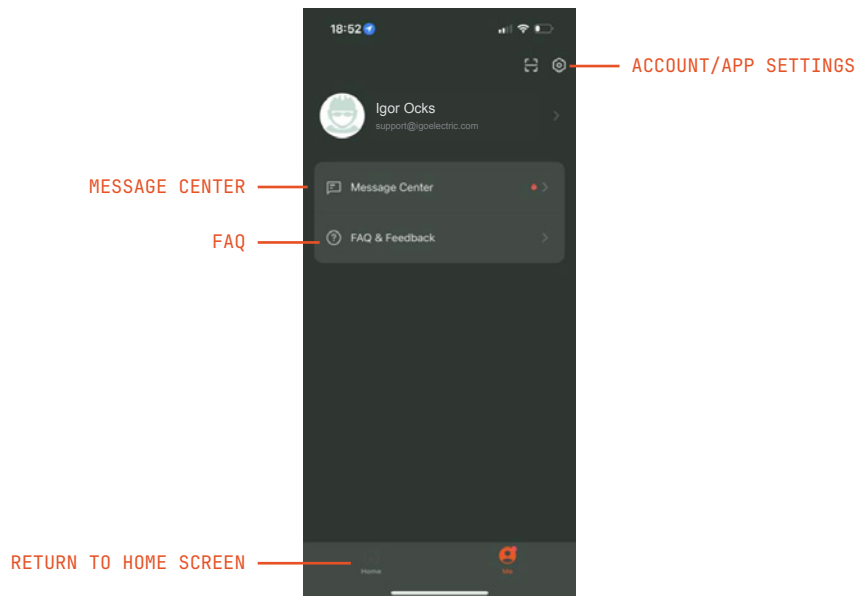

### Account/app settings

Use this menu to view and edit your personal information, preferences, account options, app settings, privacy, and security.

### Message center

Access alerts, eBike pairing/sharing logs, and communication/feedback from iGO and the support team. Use the NOTIFICATION SETTINGS menu to personalize how and when notifications from the app are scheduled and displayed.

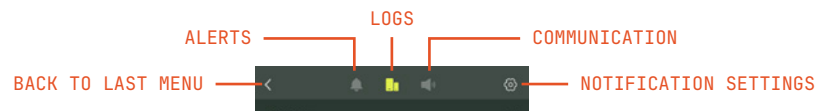

### FAQ

Information and how-to notes for common queries regarding the iGO Ride mobile app and all iGO eBikes paired to the account. Search the ever expanding knowledge base through subject specific segments or by entering keywords.

## eBIKE OPTIONS MENU

Providing options for the currently selected eBike (see page 24 to learn how to select a different bike)

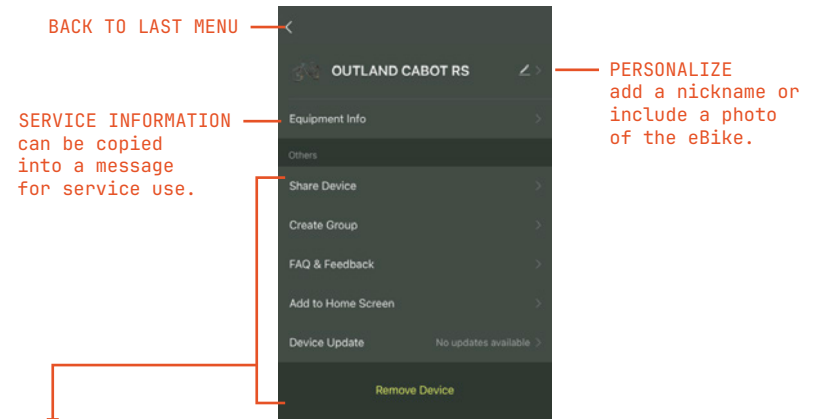

### Share Device

Share bluetooth access to the selected eBike using one of the following methods :

#### Share with iGO ride account

If you know the iGO Ride account name of the person you want to share with, enter it here.

#### Share with recent contacts

Select from a list of people you have previously shared with.

#### Share with others

Use other methods to invite people to share bluetooth access. Almost any of the communication channels on your mobile device can be used to send a message and link. The recipient must click the link and follow the instructions to accept the share invite.

### FAQ

Quick access to FAQ content specific to only the selected eBike (to access the entire database of content use the FAQ link found in the PERSONAL OPTIONS MENU see page 26)

### Add to home screen

Setup a shortcut on your mobile device home screen to open the iGO Ride mobile app with the currently selected eBike.

### Device update

Check here for any update. Current bluetooth and display firmware version will be shown.

### Remove device

Select this option if you want to remove the selected eBike from your iGO Ride account. Once removed from an account (by selecting one of the two following options) the eBike will be detectable to other iGO Ride mobile app users.

**Disconnect** : to remove the selected eBike from your iGO Ride app interface while retaining any personalization and bike data (data will be reloaded to the app if you reconnect to the bike at a later time).

**Disconnect and wipe data** : fully remove all details and personalization for the selected eBike from your iGO Ride account (this action cannot be reversed).

An iGO premium bike can also be disconnected from an iGO Ride account using the handlebar display unit. See page 9 for details.

# MECHANICAL COMPONENTS

## THE GROUPSET

A bike's groupset refers to the mechanical parts that are involved in braking, changing gears, or powering the drivetrain. This includes the shifter(s), brake levers, front and rear brake calipers, front and rear derailleurs, wheel hubs, crankset, bottom bracket, chain, and cassette.

## ABOUT GEARS AND SHIFTING

Understanding when and how to shift gears on any bike will lead to a smoother riding experience and avoid unnecessary damage to components due to excessive strain. On an electric bike efficient use of gears will also help to maximize your battery range.

Shifting gears is done so that you can maintain a constant and comfortable pedaling speed (cadence), no matter how fast you are riding. As you move faster you will want to use the shifters to 'shift up' into higher gears to stop your legs spinning too fast. As your riding speed is reduced you will want to 'shift down' to lower gears so you do not have to exert excessive pressure on the pedal to keep moving. When coming to a stop it is recommended to 'shift down' to a lower gear. This positions the drivetrain so you will always be ready to move off again in a lower (easier) gear and gradually 'shift up' through the gears as you increase speed allowing you to safely gain momentum, traction and balance.

Ideally, scan the road ahead and anticipate your shifts. This will ensure that you are in the correct gear when you need it, and avoid any problems with shifting under difficult conditions.

Note:

Always pedal forwards while shifting, the chain needs to be moving in order to perform the gear shifts.

Try to avoid extreme strain on the chain when shifting, if you are pedaling very hard (uphill or strong accelerations), ease up on the pedals slightly while continuing to pedal.

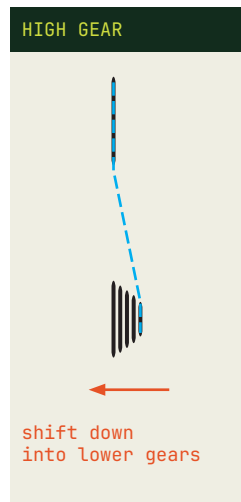
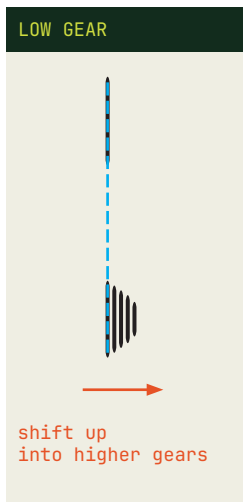

## SHIMANO TRIGGER SHIFTERS

There are 2 levers on the shifter, A and B in the diagram :

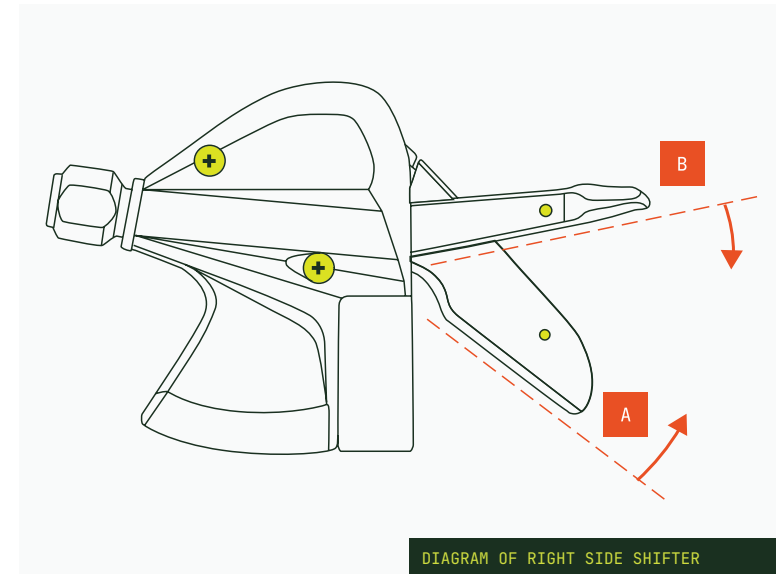

### Right side shifter

Push lever A with your thumb to 'shift down' when pedaling is too difficult. This will move the chain to a larger gear on the rear wheel, and the indicator on the shifter will show a lower number. Pedaling will be easier.

When speed increases and you are pedaling too fast, pull the lever B with your index finger to 'shift up'. This will move the chain to a smaller gear on the rear wheel, and the indicator will show a higher number. Pedaling will be harder.

# MECHANICAL COMPONENTS

for : ASPIRE CAMILLIEN CE

## MICROSHIFT DROP BAR LEVERS

The shifters incorporate 2 moving elements, the main lever and the inner lever :

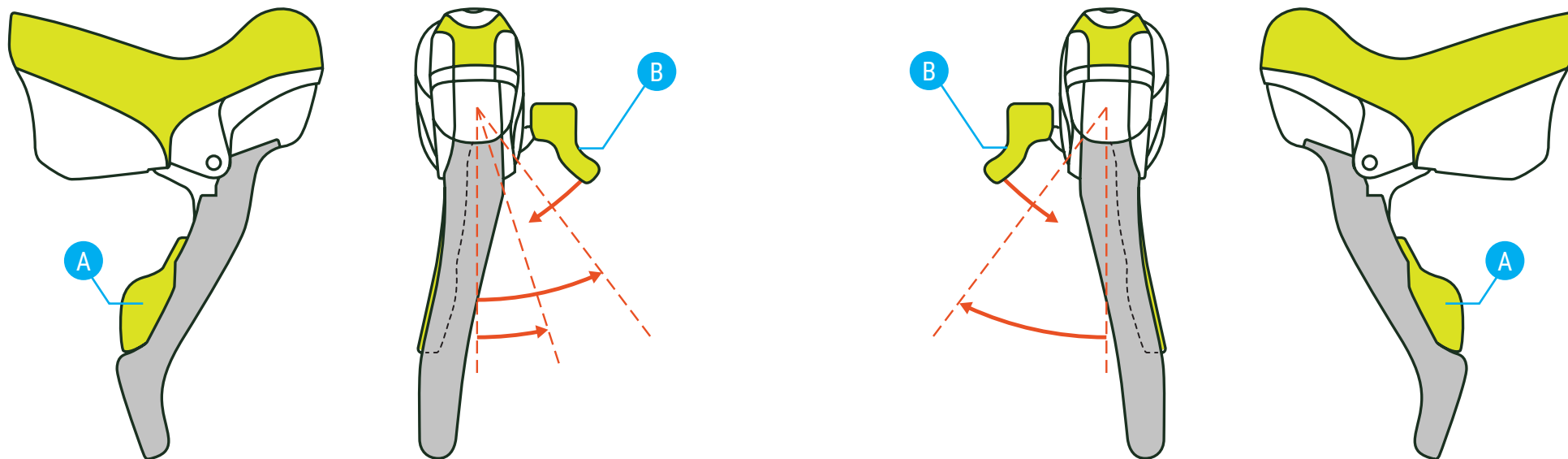

### Right side shifter

Swing the main shift lever (A) inwards with your hand to 'shift down' when pedaling is too difficult. This will move the chain to a larger gear on the rear wheel. Pedaling will be easier. When speed increases and you are pedaling too fast, move only the smaller, inner thumb lever (B) downwards to 'shift up'. This will move the chain to a smaller gear on the rear wheel. Pedaling will be harder. Multiple shifts at once are possible, by swinging the lever further.

### Left side shifter

Swing the main shift lever (A) inwards with your hand to 'shift up' when pedaling becomes easy and you are increasing your speed. This will move the chain onto a larger chainring in front. When pedaling becomes difficult, press the smaller inner lever (B) downwards to 'shift down'. This will drop the chain onto a smaller chainring and pedaling will become easier.

### CHAINRING (2X)

shift down  
into lower gears





## MECHANICAL COMPONENTS

### DISC BRAKE ALIGNMENT

Disc brakes provide increased stopping power to ensure safe control of electric bicycles.

To properly adjust disc brakes you must first make sure that the disc is properly aligned within the brake caliper. To do this, loosen the top and bottom hex bolts with an Allen key. Then manoeuvre the brake with your hand so that the disc passes through the brake pads with minimal contact. Once the disc rotates through the brake freely, retighten the hex bolts and make sure that while tightening you maintain the alignment.

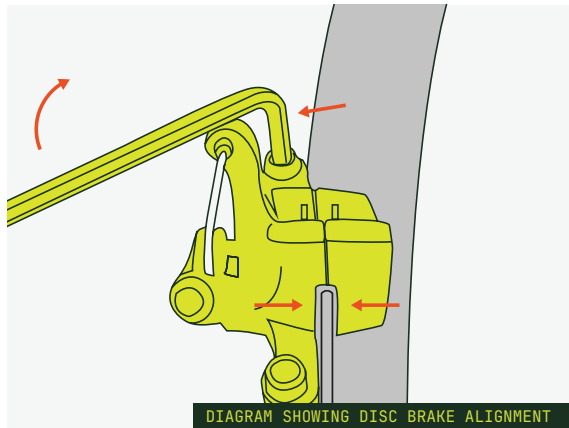

### HOW TO BED IN NEW DISC BRAKE PADS

Properly bedding in your brakes will increase the lifespan of the pads, reduce noise and increase the braking power. Before your first ride, perform this procedure to properly condition the brake pads and rotors :

1. Accelerate to a medium speed (approx. 20 km/h), then firmly apply the brakes and reduce your speed to a walking pace. Repeat approximately 20 times.
2. Accelerate to a higher speed (approx. 32 km/h), then firmly and quickly apply the brakes, reducing your speed to walking pace. Repeat approximately 10 times
3. Let the brakes cool before setting off on your first ride.

for: ASPIRE CAMILLIEN CE | THE ROYAL UF

### ADJUSTING MECHANICAL DISC BRAKES OR CABLE ACTUATED HYDRAULIC BRAKES

If squeezing the brake handle does not stop the bike properly, you will have to adjust the brakes.

First try turning the barrel adjusters located on the brake caliper and brake lever counter clockwise to increase the tension of the brake cable. If this still does not provide sufficient stopping power when the brake lever is squeezed then it is recommended to check the brake pads for wear and replace if necessary. If the pads are good and the brake cable needs further adjustment, reset the barrel adjusters to their initial position then proceed to loosen the hex bolt that retains the brake cable on the caliper with an Allen key. Once the bolt is loosened, rotate the braking arm so that the brake is squeezing the brake disc and spin the wheel. Move the brake arm back in small amounts until the wheel is spinning smoothly. Pull the brake cable tight and retighten the hex bolt.

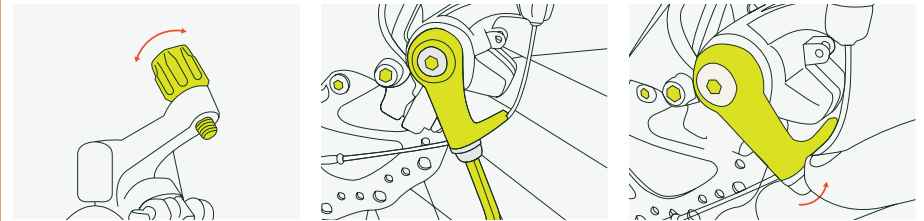

### ADJUSTING HYDRAULIC DISC BRAKES

The hydraulic brake system on your iGO electric bike is self adjusting, and will not require manual adjustment during normal operation.

If you pull the brake lever and the brakes fail stop your bike adequately, you possibly have air in your brake line or the pads are worn past the usable limit. In either case we strongly suggest this service be done by a professional bike mechanic as special tools and procedures are required

# MECHANICAL COMPONENTS

## ADJUSTABILITY AND iGO ERGOFIT

All iGO bikes are adjustable to suit individual riding position preferences.

iGO Bikes equipped with the Ergofit system have toolless adjustable reach, pitch and height allows riding posture to be adapted instantly at any time for :

- Maximum comfort and minimized muscle fatigue during long rides
- Adaptable riding styles (e.g. upright relaxed leisure to low+forward power riding)
- Ergonomically fit different rider body types on the same bike

## ADJUSTING THE SEAT HEIGHT

Your seat height should be adjusted properly to ensure you get the most comfortable ride possible. The seat height is properly adjusted when your knee has a slight bend when sitting on the saddle with your foot on the pedal at its lowest position. The seat height can be adjusted by loosening the quick release lever on the seat tube clamp. Retighten the quick release and check to make sure the saddle is straight and held securely before riding again.

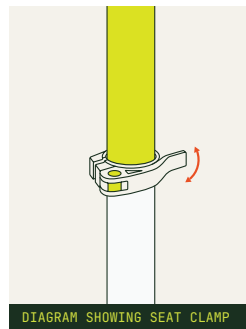

## ADJUSTING THE SADDLE POSITION

You can tilt the saddle to change the seating angle, as well as adjust the fore/aft position to suit your fit. To adjust the saddle, loosen the bolt located on the underside of the seatpost clamp, under the saddle, with an Allen key. You will be able to move the saddle back and forth, and change the angle to suit your preferred riding style. When you are done adjusting, make sure to retighten the bolt.

Note:

Ensure that the safety marks for max. height (written on the seat post) are not visible when the seat clamp is secured, and that the rails on the saddle are clamped by the seatpost only on the straight section.

When the saddle has been adjusted to your satisfaction be sure the nose is pointing straight ahead and is not twisted to either side.

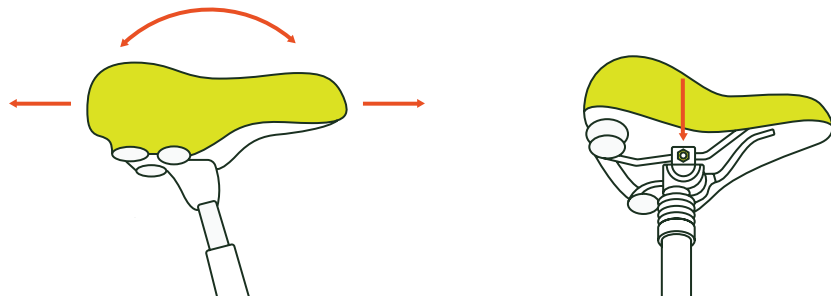

for : DISCOVERY YORKVILLE LE | DISCOVERY ROSEMONT LE

## ADJUSTING THE HANDLEBARS (QUICK RELEASE)

The adjustable stem has an effective quick-release mechanism that will allow you to unlock, adjust and retighten the stem and handlebar position.

To use, find the lock button in the middle top of the stem and slide it forward to unlock the main lever. While holding the button unlocked, lift the main lever fully up and rotate towards the front of the bike. While fully opened, you will be able to adjust both the angle of the stem and rotate the handlebars to achieve the most comfortable position.

When the handlebar is in the desired position, ensure it is centered left and right in the stem and close the main lever fully, ensuring you hear the lock button engage. Make sure that the lock is engaged by pulling up on the main lever to verify that it does not open.

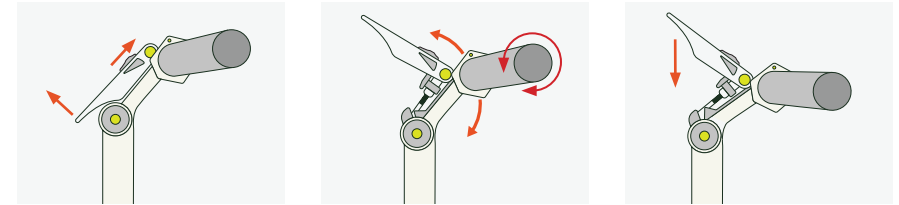

for : DISCOVERY YORKVILLE LS | DISCOVERY ROSEMONT LS | OUTLAND CABOT RS

OUTLAND SAWBACK RS | OUTLAND TORNGAT RS | ASPIRE CAMILLIEN CE | ASPIRE VENDOME CE

## INSTALLING THE HANDLEBARS (4 BOLT STEM)

Using the 4mm Allen key take off the 4 front bolts of the stem and remove the front plate. Place handlebar in position on stem, replace the front plate reinstall the 4 bolts loosely. Tighten bolts as shown; make sure to attach all bolts one at a time in order from 1 to 4 but don't fully tighten until all bolts are installed. (tighten to 5Nm - 6Nm)

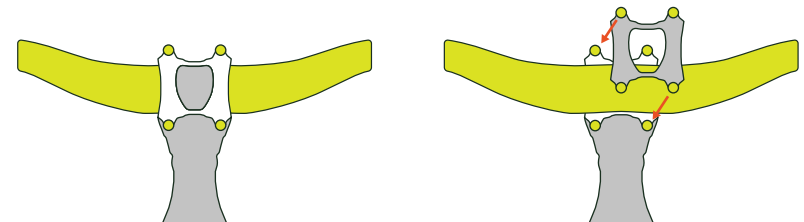

# MECHANICAL COMPONENTS

## REAR WHEEL REMOVAL AND INSTALLATION

Hub Motor equipped iGO electric bikes incorporate the drive motor, so removal and re-installation requires a few special considerations.

First, shift the bike onto the smallest cog (highest gear) to make removal and installation of the wheel easier. Next, locate and disconnect the cable that runs to the motor. Follow the wire that exits the rear hub on the right side of the bike, you will see a weatherproof connector partway between the hub and the pedal area. Disconnect this plug, either by unthreading the outer collar and then pulling the 2 halves apart or by simply pulling apart. Remove any cable ties or clips holding the wire to the frame. At this point, make sure to have the bike supported in a work stand or inverted on the ground, allowing you to safely remove the wheel. Loosen both nuts that hold the wheel onto the frame using an 18mm wrench. These nuts may have a rubber cap installed, remove these first. The wheel will be free to drop out of the frame. Before removing the wheel completely, note the location of the washers on the wheel axle so you can re-install them on the correct side of the frame. We suggest taking a photo before disassembly to ensure correct reassembly.

When re-installing the wheel, rotate the axle so that the flat sides insert into the dropouts on the frame (a 10mm wrench will help to turn the axle to the correct orientation). Pay attention to the brake rotor, make sure that it slides in between the brake pads on the brake caliper. The chain should sit on the smallest gear, as it was when the wheel was removed. Tighten the nuts hand-tight, then make sure that the wheel is sitting fully inserted into the frame and the rim/tire is centered in the frame and not rubbing on either side. Tighten the nuts to 25-30 Nm. Replug the motor wire connector, making sure that the 2 halves are correctly oriented, and that the pins are straight and clean. Re-thread the locking collar if present, and verify that the connection is fully plugged in. Check the brake and shifter operation before riding.

## TIRE PRESSURE

The tire pressure will affect the range and comfort of your bike. iGO recommends that you always keep your tires at the designated pressure to ensure the best ride. The recommended tire pressure is written on the sidewall of the tire.

Tire pressure is measured in P.S.I. (Pounds / Square Inch).

Make sure to use a tire pressure gauge when inflating your tires to ensure the correct tire pressure.

## ADJUSTING THE SUSPENSION FORK

Many iGO electric bikes are equipped with a suspension fork with a lockout. By turning the lever on the top of the right fork leg in the direction indicated, you are able to 'lockout', or stiffen up the fork for more efficient riding. The stiffness of the fork will increase as the lever is turned further. Turning the lever to the limit will make the fork completely rigid, which is useful for efficient riding on smooth roads. Turn the knob in the opposite direction to take full advantage of the suspension to absorb the shocks from rough roads, increase comfort and ensure your front wheel stays in better contact with the road, providing more grip and confidence when turning or braking.

On forks with adjustable preload, the left leg top cap will be equipped with an adjuster knob that will allow you to stiffen or soften the suspension to suit your weight and comfort requirements.

On bikes equipped with an air suspension fork, the air spring in the left leg can be adjusted with a shock pump to make the fork stiffer or softer, according to your weight and comfort requirements.

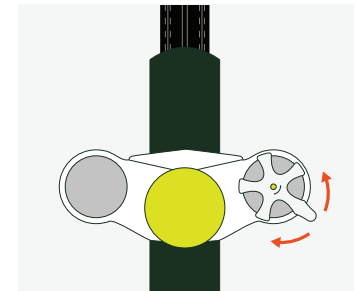

## QUICK RELEASE, Q-LOC, AND THRU AXLE FORK

for: DISCOVERY YORKVILLE LE | DISCOVERY ROSEMONT LE  
ASPIRE CAMILLIEN CE | ASPIRE VENDOME CE | THE ROYAL UF

### How to fasten the quick release hub

1. Move the quick release lever to the OPEN position and set the wheel so it firmly touches the interior of the fork end.
2. Open and close the quick release lever with your right hand while gradually tightening the adjusting nut clockwise with your left. Continue tightening the nut until you feel resistance from the lever when it reaches parallel position with the hub
3. Grip the fork blade with your fingers and use the palm of your hand to apply force to the quick release lever. It should take considerable force against to tighten the lever completely. The word "CLOSE" inscribed in the lever should face out. The lever should be in front of, and parallel to the fork blade
4. Note if the quick release lever can be easily pushed to the CLOSE position, this means the clamping force is insufficient. Return the quick release lever to parallel position with the hub and again turn the adjusting nut clockwise to increase the clamping force. Push the quick release lever back to the CLOSE position.
5. If the clamping force is adjusted too strong and the quick release lever cannot be pushed to the CLOSE position, turn the adjusting nut counter-clockwise to reduce the clamping force. When doing this, do not over loosen the adjust nut. Rotate the adjusting nut 1/8th of a turn then push the lever to CLOSE position. Repeat this procedure until maximum clamping force is achieved by hand.

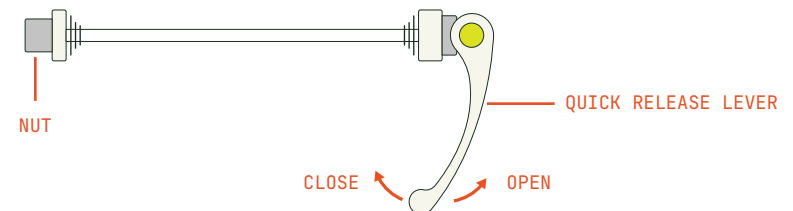

# MECHANICAL COMPONENTS

for : OUTLAND CABOT RS | OUTLAND SAWBACK RS

## Q-LOC assembly

1. Check the segmented flange is expanded before installation. Open the lever completely.
2. Slide in the axle until it "clicks". Make sure the segmented flange is expanded.
3. Set the tension of the nut until the flange is flush with the dropout.
4. Close the lever completely. Check if it's firmly seated. Re-tighten the nut if necessary.

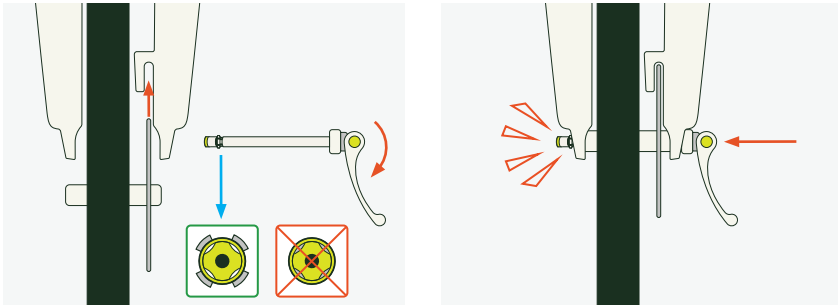

## Q-LOC removal

1. Open the lever completely.
2. Press and turn adjust nut clockwise until segmented flange retracts and stays latched.
3. Pull out the axle.

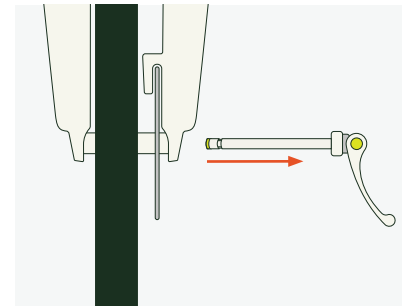
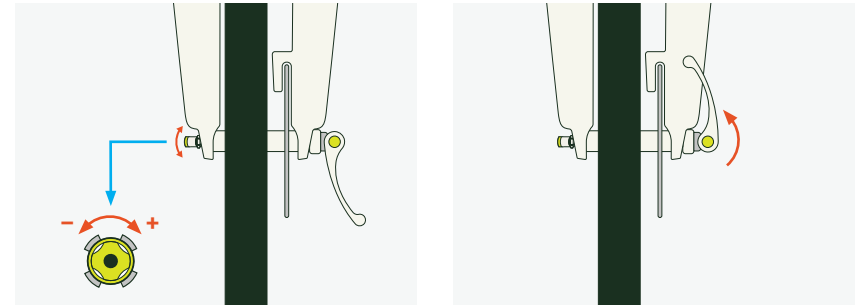
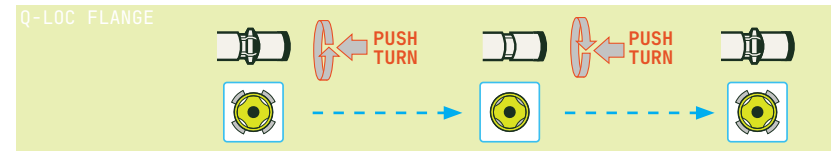
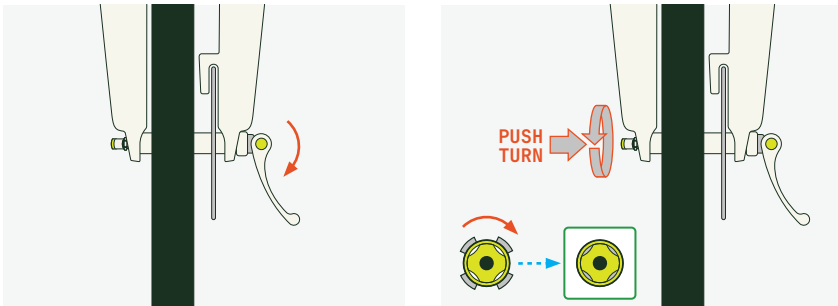

for : DISCOVERY YORKVILLE LS | DISCOVERY ROSEMONT LS | OUTLAND TORNGAT RS

## Axle assembly for front 15mm thru-axle

1. Position your front wheel into the dropouts of the lower fork leg. As you are installing the front wheel, be sure to squarely position the brake rotor in between the brake pads of the disc caliper. The hub shoulders should seat squarely and firmly in the dropout counterbores.
2. Insert the axle into the left side of the fork dropout and slide it all the way through the hub, until you contact the axle nut on the other side.
3. Using a 6mm Allen key, thread the axle into the axle nut five to six (5-6) complete turns and tighten to 10-15Nm.

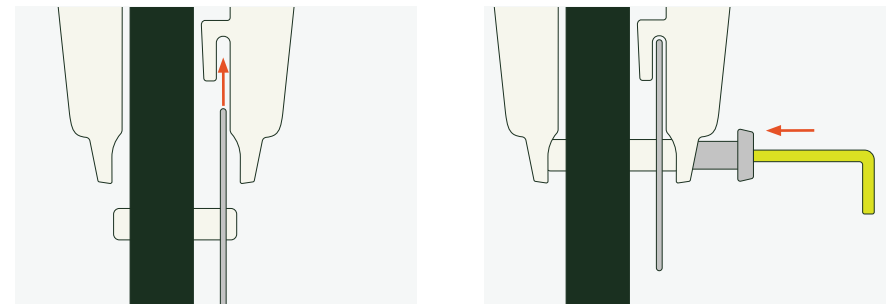

# FOLDING FRAME

for: THE ROYAL UF

## FOLDING / UNFOLDING

Follow these simple steps to fold your electric bike :

### STEP 1 (pedals)

Push the outside edge of the pedal towards the frame and fold until the folding section is parallel to the frame

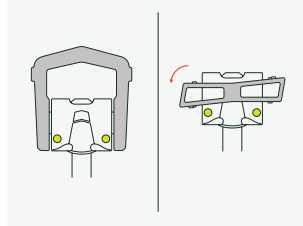

### STEP 2 (handlebar and stem)

Release the 'safety catch' mechanism on the stem by rotating clockwise or lifting the knob depending on which version of the lock is on your bike. Open the quick release lever by pulling away from the stem and lowering.

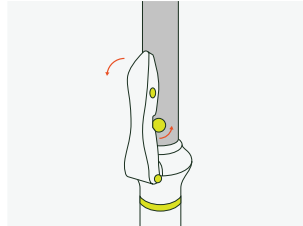

### STEP 3

Fold handlebars to the side of the bike frame as shown in the picture. (Pay attention not to force cabling. The cables should fall in front or behind the stem when folded, not forced over the folding mechanism.)

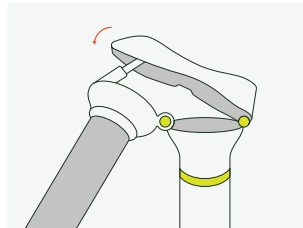

### STEP 4 (frame)

Release the 'safety catch' mechanism located close to the bottom bracket by lifting. Pull on the quick release lever to unlock the frame hinge then push the lever back towards the front of the frame to fully clear the latch from the locking mechanism.

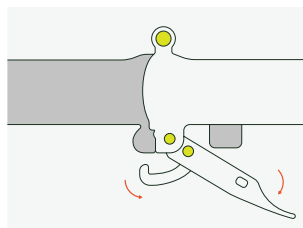

### STEP 5

Lift the kickstand then rotate the front end of the bike until the front and rear wheels are next to each other. The bike can now be supported by the metal stand situated under the bottom bracket.

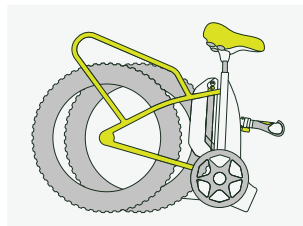

To fold your electric bike repeat the steps in reverse order.

## ADJUSTING THE HANDLEBAR POSITION (FOLDING STEM)

You can adjust the height of the handlebar by opening the quick release lever and lifting or lowering the stem to the desired height. Once the height is set close the quick release lever to lock the position.

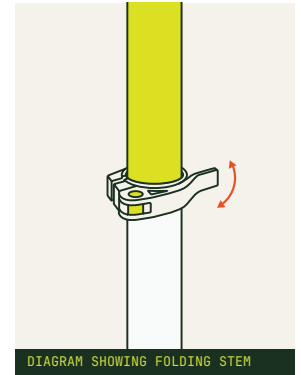

## ALWAYS MAKE SURE ALL SAFETY CATCHES ARE FULLY ENGAGED BEFORE RIDING YOUR FOLDING ELECTRIC BIKE

### STEM SAFETY CATCH

The stem safety catch is fully engaged when turned counterclockwise, or the knob is in the lowest position, and the release lever cannot be opened.

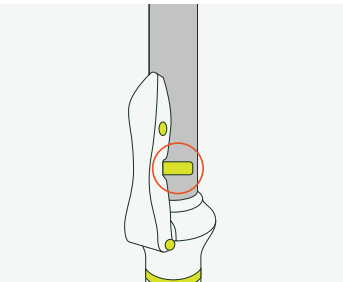

### FRAME SAFETY CATCH

The frame safety catch is fully engaged when rotated down and the release lever cannot be opened.

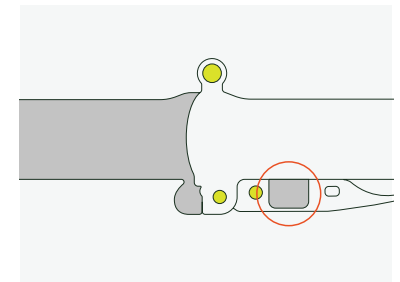

# iGO ASSIST

## WHAT IS iGO ASSIST

iGO's ever expanding knowledge base with guides, tips, and tricks to optimize your experience through every step of your journey.

iGO Assist provides access to user manuals, assembly videos, FAQ, live chat and email/ phone support – iGO Assist can deliver everything you need to get on an electric bike for the first time; it will answer any questions you may have during your ride, and can share expert tips and tricks to make sure you always get the most from your iGO electric bike.

If you still require further assistance you can submit a support request through the iGO Assist portal.

## HOW TO ACCESS iGO ASSIST

To access iGO Assist online visit :

[assist.igoelectric.com](http://assist.igoelectric.com)

Chose from general FAQ, bike model specific documents and videos, chat support, or ask detailed questions with ability to include photos that our dedicated support team can use for to reference when responding.

To take full advantage of all iGO customer support options your eBike must be registered.

### Advanced diagnostics

A wealth of in-depth diagnostic information (intended to speed up and simplify support and servicing of your iGO electric bike) can be accessed through the iGO Ride app. Should any advanced diagnostic information be required, the iGO support representative or an iGO certified mechanic will identify and extract the relevant information for you.



The following pages provide some relevant information to assist in the continued enjoyment and maintenance your new iGO eBike.

## DIAGNOSTICS AND WARNING CODES

If a diagnostic (warning/error) code appears on the eBike's display unit, identify the issue from this table and take the appropriate action.

Diagnostic code	Description	Suggested action
1	Synchronous motor signal overcurrent warning	Check motor connections, unplug and ensure pins are aligned correctly and the connection is fully secured.
2	Controller overcurrent warning	Power off system and restart. Check controller connections, unplug and ensure pins are aligned correctly and the connection is fully secured.
3	Hall sensor signal warning	Avoid stalling the motor. Check motor connections, unplug and ensure pins are aligned correctly and the connection is fully secured.
4	Brake lever sensor fault	Check the weatherproof connector to the brake cut-off sensor. Ensure pins are aligned correctly and the connection is fully secured. Check brake lever for damage and ensure lever retracts to the fully open position.
5	Controller temperature warning	Allow the controller to cool down for a short period of time.
6	Motor temperature warning	Allow the motor to cool down for a short period of time.
8	Controller communication fault	Verify cable harness and weatherproof connectors for damage or disconnections.
9	Controller voltage warning	Check condition of battery and battery connections. Try a different battery if it is available.
10	Other faults	Contact iGO Support
21	Controller overcurrent warning	Power off system and restart. Check controller connections, unplug and ensure pins are aligned correctly and the connection is fully secured.
24	Hall sensor signal warning	Avoid stalling the motor. Check motor connections, unplug and ensure pins are aligned correctly and the connection is fully secured.
25	Brake lever sensor fault	Check the weatherproof connector to the brake cut-off sensor. Ensure pins are aligned correctly and the connection is fully secured. Check brake lever for damage and ensure lever retracts to the fully open position.
28	Regional settings warning	Perform system update.
30	Communication fault	Check the display cable and weatherproof connector to the display unit. Ensure pins are aligned correctly and the connection is fully secured. Verify cable harness and weatherproof connectors for damage or disconnections.
31	Regional settings warning	Perform system update.
36	Torque value fault	Power off system and restart without putting pressure on the pedals.

If the code persists contact iGO support.

## MAIN TECHNICAL PARAMETERS, SPECIFICATIONS, AND PARTS

DISCOVERY ROSEMONT LE SKU : 100-211-000

PART	DESCRIPTION
FRAME	Hydroformed Aluminum Step Through 45.7cm (18")
COLOR	Off White
FORK	RST VOLANT suspension with lockout, quick release
SHIFTERS	SHIMANO ALTUS 8-speed
CHAINRINGS	42T Narrow Wide teeth
CHAIN	KMC E8-S
REAR DERAILLEUR	SHIMANO ACERA 8-speed
CASSETTE	SHIMANO ACERA 8-speed 11-32T
HANDLEBAR	630mm, 21mm rise, 31.8mm dia.
STEM	Toolless adjustable threadless, 0 to 90 degree rise
SEAT POST	31.6mm, quick release (350mm)
SADDLE	SELLE ROYAL Rio
BRAKE LEVERS	TEKTRO HD-E350
BRAKE CALIPERS	TEKTRO HD-E350 hydraulic disc
ROTORS	180mm
TIRES	27.5"x2.4"
RIMS	27.5" dual wall alloy, black
DISPLAY	2" HD High Brightness IPS Color LCD Display
BLUETOOTH	compatible with iGO RIDE mobile app (Android & iOS)
MOTOR	500W geared rear hub motor, 48V
TORQUE	up to 55Nm
CONTROLLER	48V high power FOC, Uart/Can
BATTERY	5000mAh SAMSUNG Cell Lithium-Ion 48V / 15Ah / 720Wh
RANGE	110km (69mi) *
PAS	Eco/Tour/Sport/Turbo/Boost color coded pedal assist segments
THROTTLE	Any time on demand thumb throttle - removable
SENSOR	Electronic 32 pulse Cadence Sensor
CHARGER	48V, 3A, 4 pin, UL Certified
CHARGING TIME	4 to 6 hours
CLASS	MULTI-CLASS SWITCHABLE : Class2 / Class1 optional / Class3 capable where permitted **
BIKE WEIGHT	25.9kg (57.1 lbs)
BATTERY WEIGHT	3.5kg (7.7 lbs)
WEIGHT CAPACITY	125 kg (275 lbs)

Specifications subject to change

\*Actual range may vary depending on Ah of battery rider weight and other riding conditions.

\*\*Electric bike class regulation:

Class 1 : No throttle function, PAS with maximum speed 32km/h (20mph)

Class 2 : Throttle and PAS maximum speed 32km/h (20mph)

Class 3 : Throttle maximum speed 32km/h (20mph), PAS maximum speed 45km/h (28mph)

all classes allow a maximum motor power of 750W(US) or 500W(Canada)

## MAIN TECHNICAL PARAMETERS, SPECIFICATIONS, AND PARTS

DISCOVERY YORKVILLE LE SKU : 100-221-000

PART	DESCRIPTION
FRAME	Hydroformed Aluminum Hybrid 48cm (19")
COLOR	Black
FORK	RST VOLANT suspension with lockout, quick release
SHIFTERS	SHIMANO ALTUS 8-speed
CHAINRINGS	42T Narrow Wide teeth
CHAIN	KMC E8-S
REAR DERAILLEUR	SHIMANO ACERA 8-speed
CASSETTE	SHIMANO ACERA 8-speed 11-32T
HANDLEBAR	640mm, 16mm rise, 31.8mm dia.
STEM	Toolless adjustable threadless, 0 to 90 degree rise
SEAT POST	31.6mm, quick release (350mm)
SADDLE	SELLE ROYAL Rio
BRAKE LEVERS	TEKTRO HD-E350
BRAKE CALIPERS	TEKTRO HD-E350 hydraulic disc
ROTORS	180mm
TIRES	27.5"x2.4"
RIMS	27.5" dual wall alloy, black
DISPLAY	2" HD High Brightness IPS Color LCD Display
BLUETOOTH	compatible with iGO RIDE mobile app (Android & iOS)
MOTOR	500W geared rear hub motor, 48V
TORQUE	up to 55Nm
CONTROLLER	48V high power FOC, Uart/Can
BATTERY	5000mAh SAMSUNG Cell Lithium-Ion 48V / 15Ah / 720Wh
RANGE	110km (69mi) *
PAS	Eco/Tour/Sport/Turbo/Boost color coded pedal assist segments
THROTTLE	Any time on demand thumb throttle - removable
SENSOR	Electronic 32 pulse Cadence Sensor
CHARGER	48V, 3A, 4 pin, UL Certified
CHARGING TIME	4 to 6 hours
CLASS	MULTI-CLASS SWITCHABLE : Class2 / Class1 optional / Class3 capable where permitted **
BIKE WEIGHT	25.7kg (56.7 lbs)
BATTERY WEIGHT	3.5kg (7.7 lbs)
WEIGHT CAPACITY	125 kg (275 lbs)

Specifications subject to change

\*Actual range may vary depending on Ah of battery rider weight and other riding conditions.

\*\*Electric bike class regulation:

Class 1 : No throttle function, PAS with maximum speed 32km/h (20mph)

Class 2 : Throttle and PAS maximum speed 32km/h (20mph)

Class 3 : Throttle maximum speed 32km/h (20mph), PAS maximum speed 45km/h (28mph)

all classes allow a maximum motor power of 750W(US) or 500W(Canada)

## MAIN TECHNICAL PARAMETERS, SPECIFICATIONS, AND PARTS

DISCOVERY ROSEMONT LS SKU : 100-212-000

PART	DESCRIPTION
FRAME	Hydroformed Aluminum Step Through 45cm (17.7")
COLOR	Burgundy
FORK	RST BLAZE-27.5TNL-15 suspension with lockout, thru axle
SHIFTERS	SHIMANO ALIVIO 9-speed Rapidfire Plus
CHAINRINGS	42T Narrow Wide teeth
CHAIN	KMC E9-S
REAR DERAILLEUR	SHIMANO ALIVIO 9-speed
CASSETTE	SHIMANO ALIVIO 9-speed 11-34T
HANDLEBAR	640mm, 45mm rise, 31.8mm dia.
STEM	80mm, 7 degree rise
SEAT POST	31.6mm (350mm)
SADDLE	SELLE ROYAL Rio
BRAKE LEVERS	TEKTRO HD-E350
BRAKE CALIPERS	TEKTRO HD-E350 hydraulic disc
ROTORS	180mm
TIRES	27.5"x2.4"
RIMS	27.5" dual wall alloy, black
DISPLAY	2" HD High Brightness IPS Color LCD Display
BLUETOOTH	compatible with iGO RIDE mobile app (Android & iOS)
MOTOR	350W mid motor, 48V
TORQUE	up to 100Nm
BATTERY	5000mAh SAMSUNG Cell Lithium-Ion 48V / 15Ah / 720Wh
RANGE	110km (69mi) *
PAS	Eco/Tour/Sport/Turbo/Boost color coded pedal assist segments
THROTTLE	Any time on demand thumb throttle - removable
SENSOR	Internal Torque, Cadence, Speed
CHARGER	48V, 3A, 4 pin, UL Certified
CHARGING TIME	4 to 6 hours
CLASS	MULTI-CLASS SWITCHABLE : Class2 / Class1 optional / Class3 capable where permitted **
BIKE WEIGHT	25.3kg (55.8 lbs)
BATTERY WEIGHT	3.5kg (7.7 lbs)
WEIGHT CAPACITY	125 kg (275 lbs)

Specifications subject to change

\*Actual range may vary depending on Ah of battery rider weight and other riding conditions.

\*\*Electric bike class regulation:

Class 1 : No throttle function, PAS with maximum speed 32km/h (20mph)

Class 2 : Throttle and PAS maximum speed 32km/h (20mph)

Class 3 : Throttle maximum speed 32km/h (20mph), PAS maximum speed 45km/h (28mph)

all classes allow a maximum motor power of 750W(US) or 500W(Canada)

## MAIN TECHNICAL PARAMETERS, SPECIFICATIONS, AND PARTS

DISCOVERY YORKVILLE LS SKU : 100-222-000

PART	DESCRIPTION
FRAME	Hydroformed Aluminum Hybrid 48cm (19")
COLOR	Platinum
FORK	RST BLAZE-27.5TNL-15 suspension with lockout, thru axle
SHIFTERS	SHIMANO ALIVIO 9-speed Rapidfire Plus
CHAINRINGS	42T Narrow Wide teeth
CHAIN	KMC E9-S
REAR DERAILLEUR	SHIMANO ALIVIO 9-speed
CASSETTE	SHIMANO ALIVIO 9-speed 11-34T
HANDLEBAR	640mm, 45mm rise, 31.8mm dia.
STEM	80mm, 7 degree rise
SEAT POST	31.6mm (350mm)
SADDLE	SELLE ROYAL Rio
BRAKE LEVERS	TEKTRO HD-E350
BRAKE CALIPERS	TEKTRO HD-E350 hydraulic disc
ROTORS	180mm
TIRES	27.5"x2.4"
RIMS	27.5" dual wall alloy, black
DISPLAY	2" HD High Brightness IPS Color LCD Display
BLUETOOTH	compatible with iGO RIDE mobile app (Android & iOS)
MOTOR	350W mid motor, 48V
TORQUE	up to 100Nm
BATTERY	5000mAh SAMSUNG Cell Lithium-Ion 48V / 15Ah / 720Wh
RANGE	110km (69mi) *
PAS	Eco/Tour/Sport/Turbo/Boost color coded pedal assist segments
THROTTLE	Any time on demand thumb throttle - removable
SENSOR	Internal Torque, Cadence, Speed
CHARGER	48V, 3A, 4 pin, UL Certified
CHARGING TIME	4 to 6 hours
CLASS	MULTI-CLASS SWITCHABLE : Class2 / Class1 optional / Class3 capable where permitted **
BIKE WEIGHT	25.5kg (56.2 lbs)
BATTERY WEIGHT	3.5kg (7.7 lbs)
WEIGHT CAPACITY	125 kg (275 lbs)

Specifications subject to change

\*Actual range may vary depending on Ah of battery rider weight and other riding conditions.

\*\*Electric bike class regulation:

Class 1 : No throttle function, PAS with maximum speed 32km/h (20mph)

Class 2 : Throttle and PAS maximum speed 32km/h (20mph)

Class 3 : Throttle maximum speed 32km/h (20mph), PAS maximum speed 45km/h (28mph)

all classes allow a maximum motor power of 750W(US) or 500W(Canada)



## MAIN TECHNICAL PARAMETERS, SPECIFICATIONS, AND PARTS

OUTLAND CABOT RS SKU : 100-322-100

PART	DESCRIPTION
FRAME	Hydroformed Aluminum Trekking 48cm (19")
COLOR	Green and Black
FORK	Suntour XCM32 HLO DS suspension with lockout, Q-Loc thru axle
SHIFTERS	SHIMANO ALIVIO 9-speed Rapidfire Plus
CHAINRINGS	42T Narrow Wide teeth
CHAIN	KMC E9-S
REAR DERAILLEUR	SHIMANO ALIVIO 9-speed
CASSETTE	SHIMANO ALIVIO 9-speed 11-34T
HANDLEBAR	720mm, 28mm rise, 31.8mm dia.
STEM	45mm with 3 degree rise, 31.8mm clamp dia.
SEAT POST	31.6mm (350mm)
SADDLE	SELLE ROYAL
BRAKE LEVERS	TEKTRO HD-E350
BRAKE CALIPERS	TEKTRO HD-E350 hydraulic disc
ROTOR	180mm
TIRES	27.5"x2.4"
RIMS	27.5" dual wall alloy, black
DISPLAY	2" HD High Brightness IPS Color LCD Display
BLUETOOTH	compatible with iGO RIDE mobile app (Android & iOS)
MOTOR	500W mid motor, 48V
TORQUE	up to 130Nm
BATTERY	5000mAh SAMSUNG Cell Lithium-Ion 48V / 15Ah / 720Wh
RANGE	95km (60mi) *
PAS	Eco/Tour/Sport/Turbo/Boost color coded pedal assist segments
THROTTLE	Any time on demand thumb throttle - removable
SENSOR	Internal Torque, Cadence, Speed
CHARGER	48V, 3A, 4 pin, UL Certified
CHARGING TIME	4 to 6 hours
CLASS	MULTI-CLASS SWITCHABLE : Class2 / Class1 optional / Class3 capable where permitted **
BIKE WEIGHT	23.3kg (51.4 lbs)
BATTERY WEIGHT	3.5kg (7.7 lbs)
WEIGHT CAPACITY	125 kg (275 lbs)

Specifications subject to change

\*Actual range may vary depending on Ah of battery rider weight and other riding conditions.

\*\*Electric bike class regulation:

Class 1 : No throttle function, PAS with maximum speed 32km/h (20mph)

Class 2 : Throttle and PAS maximum speed 32km/h (20mph)

Class 3 : Throttle maximum speed 32km/h (20mph), PAS maximum speed 45km/h (28mph)

all classes allow a maximum motor power of 750W(US) or 500W(Canada)

## MAIN TECHNICAL PARAMETERS, SPECIFICATIONS, AND PARTS

OUTLAND SAWBACK RS SKU : 100-322-200

PART	DESCRIPTION
FRAME	Hydroformed Aluminum Hardtail 27.5 MTB 48cm (19")
COLOR	Celeste and Black
FORK	SUNTOUR SF-18 27.5" XM34-DS-Boost-LO suspension with lockout, Q-Loc thru axle
SHIFTERS	SHIMANO ALIVIO 9-speed Rapidfire Plus
CHAINRINGS	34T Narrow Wide teeth
CHAIN	KMC E9-S
REAR DERAILLEUR	SHIMANO ALIVIO 9-speed
CASSETTE	SHIMANO ALIVIO 9-speed 11-36T
HANDLEBAR	720mm, 28mm rise, 31.8mm dia.
STEM	45mm with 3 degree rise, 31.8mm clamp dia.
SEAT POST	EXA KSP900-1 Dropper Post, 31.6mm, 150mm travel (445mm)
SADDLE	SELLE ROYAL Viento
BRAKE LEVERS	TEKTRO HD-E350
BRAKE CALIPERS	TEKTRO HD-E350 hydraulic disc
ROTOR	180mm
TIRES	27.5"x2.4"
RIMS	27.5" dual wall alloy, black
DISPLAY	2" HD High Brightness IPS Color LCD Display
BLUETOOTH	compatible with iGO RIDE mobile app (Android & iOS)
MOTOR	500W mid motor, 48V
TORQUE	up to 130Nm
BATTERY	5000mAh SAMSUNG Cell Lithium-Ion 48V / 15Ah / 720Wh
RANGE	70km (45mi) *
PAS	Eco/Tour/Sport/Turbo/Boost color coded pedal assist segments
THROTTLE	Any time on demand thumb throttle - removable
SENSOR	Internal Torque, Cadence, Speed
CHARGER	48V, 3A, 4 pin, UL Certified
CHARGING TIME	4 to 6 hours
CLASS	MULTI-CLASS SWITCHABLE : Class2 / Class1 optional / Class3 capable where permitted **
BIKE WEIGHT	27.4kg (60.4 lbs)
BATTERY WEIGHT	3.5kg (7.7 lbs)
WEIGHT CAPACITY	125 kg (275 lbs)

Specifications subject to change

\*Actual range may vary depending on Ah of battery rider weight and other riding conditions.

\*\*Electric bike class regulation:

Class 1 : No throttle function, PAS with maximum speed 32km/h (20mph)

Class 2 : Throttle and PAS maximum speed 32km/h (20mph)

Class 3 : Throttle maximum speed 32km/h (20mph), PAS maximum speed 45km/h (28mph)

all classes allow a maximum motor power of 750W(US) or 500W(Canada)

## MAIN TECHNICAL PARAMETERS, SPECIFICATIONS, AND PARTS

OUTLAND TORNGAT RS SKU : 100-322-300

PART	DESCRIPTION
FRAME	Hydroformed Aluminum Fatbike 48.5cm (19.1")
COLOR	Red and Black
FORK	RST RENEGADE 26" suspension with lockout, thru axle
SHIFTERS	SHIMANO ALIVIO 9-speed Rapidfire Plus
CHAINRINGS	34T Narrow Wide teeth
CHAIN	KMC E9-S
REAR DERAILLEUR	SHIMANO ALIVIO 9-speed
CASSETTE	SHIMANO ALIVIO 9-speed 11-36T
HANDLEBAR	700mm, 28mm rise, 31.8mm dia.
STEM	75mm with 3 degree rise, 31.8mm clamp dia.
SEAT POST	EXA KSP900-1 Dropper Post, 150mm travel (445mm)
SADDLE	SELLE ROYAL Viento
BRAKE LEVERS	TEKTRO HD-E350
BRAKE CALIPERS	TEKTRO HD-E350 hydraulic disc
ROTORS	180mm
TIRE (front)	front specific 26"x4.8"
TIRE (rear)	rear specific 26"x4.8"
RIMS	26"x95mm Fat bike rim
DISPLAY	2" HD High Brightness IPS Color LCD Display
BLUETOOTH	compatible with iGO RIDE mobile app (Android & iOS)
MOTOR	500W mid motor, 48V
TORQUE	up to 130Nm
BATTERY	5000mAh SAMSUNG Cell Lithium-Ion 48V / 15Ah / 720Wh
RANGE	60km (37mi) *
PAS	Eco/Tour/Sport/Turbo/Boost color coded pedal assist segments
THROTTLE	Any time on demand thumb throttle - removable
SENSOR	Internal Torque, Cadence, Speed
CHARGER	48V, 3A, 4 pin, UL Certified
CHARGING TIME	4 to 6 hours
CLASS	MULTI-CLASS SWITCHABLE : Class2 / Class1 optional / Class3 capable where permitted **
BIKE WEIGHT	26.9kg (59.3 lbs)
BATTERY WEIGHT	3.5kg (7.7 lbs)
WEIGHT CAPACITY	125 kg (275 lbs)

Specifications subject to change

\*Actual range may vary depending on Ah of battery rider weight and other riding conditions.

\*\*Electric bike class regulation:

Class 1 : No throttle function, PAS with maximum speed 32km/h (20mph)

Class 2 : Throttle and PAS maximum speed 32km/h (20mph)

Class 3 : Throttle maximum speed 32km/h (20mph), PAS maximum speed 45km/h (28mph)

all classes allow a maximum motor power of 750W(US) or 500W(Canada)

## MAIN TECHNICAL PARAMETERS, SPECIFICATIONS, AND PARTS

THE ROYAL UF SKU : 100-511-001 (red) | 100-511-002 (black)

PART	DESCRIPTION
FRAME	Hydroformed Aluminum Foldable Step Through 42cm (16.5")
COLOR	Kandy Apple Red or Gloss Jet Black
FORK	WB800 - 20" suspension, quick release
SHIFTERS	SHIMANO 8-speed trigger shift
CHAINRINGS	52T
CHAIN	KMC Z7
REAR DERAILLEUR	SHIMANO ALTUS 8-speed
CASSETTE	SHIMANO 8-speed 11-32T
HANDLEBAR	Alloy flat bar 600mm
STEM	Adjustable height folding stem
SEAT POST	27.2mm suspension with quick release (350mm)
SADDLE	SELLE ROYAL
BRAKE LEVERS	Mechanical brake lever with cut-off
BRAKE CALIPERS	TEKTRO ARIES mechanical disc
ROTORS	180mm
TIRES	20"x4"
RIMS	Alloy fat 20"
DISPLAY	2" HD High Brightness IPS Color LCD Display
BLUETOOTH	compatible with iGO RIDE mobile app (Android & iOS)
MOTOR	500W geared rear hub motor, 48V
TORQUE	up to 80Nm
CONTROLLER	48V high power FOC, 22 Amp, Uart Bluetooth
BATTERY	2600mAh LG Cell Lithium-Ion 48V / 13Ah / 624Wh
RANGE	60km (37mi) *
PAS	Eco/Tour/Sport/Turbo/Boost color coded pedal assist segments
THROTTLE	Any time on demand thumb throttle - removable
SENSOR	Electronic 32 pulse Cadence Sensor
CHARGER	48V, 3A, 4 pin, UL Certified
CHARGING TIME	4 to 6 hours
CLASS	MULTI-CLASS SWITCHABLE : Class2 / Class1 optional / Class3 capable where permitted **
BIKE WEIGHT	25.8kg (56.9 lbs)
BATTERY WEIGHT	3.7kg (8.2 lbs)
WEIGHT CAPACITY	114 kg (250 lbs)

Specifications subject to change

\*Actual range may vary depending on Ah of battery rider weight and other riding conditions.

\*\*Electric bike class regulation:

Class 1 : No throttle function, PAS with maximum speed 32km/h (20mph)

Class 2 : Throttle and PAS maximum speed 32km/h (20mph)

Class 3 : Throttle maximum speed 32km/h (20mph), PAS maximum speed 45km/h (28mph)

all classes allow a maximum motor power of 750W(US) or 500W(Canada)

## iGO ASSIST

## MAIN TECHNICAL PARAMETERS, SPECIFICATIONS, AND PARTS

ASPIRE CAMILLIEN CE SKU : 100-121-148 (48") | 100-121-154 (54")

PART	DESCRIPTION
FRAME	Hydroformed Aluminum Gravel Road - 48cm (19") or 54cm (21")
COLOR	Matte Taupe with Black accents
FORK	Hydroformed alloy 700C, quick release
SHIFTERS	MICROSHIFT CENTOS 2x10 Dual Control Levers
FRONT DERAILLEUR	MICROSHIFT CENTOS FD-R712-B
CHAINRINGS	48/32T
CHAIN	KMC X10
REAR DERAILLEUR	MICROSHIFT CENTOS 10-speed RD-R51M Black
CASSETTE	MICROSHIFT CENTOS 10-speed CS-H100 11-32T
HANDLEBAR	Alloy drop bar, 420mm
STEM	4 bolt, 90mm, 31.8mm clamp dia.
SEAT POST	30.4mm with quick release (350mm)
SADDLE	VELO for iGO
BRAKE LEVERS	TEKTRO TRP HY
BRAKE CALIPERS	TEKTRO Cable Actuated Hydraulic Disc HY/RD
ROTOR	160mm
TIRES	700X42C - tanwall
RIMS	Alloy P23D 700C - black
DISPLAY	???
BLUETOOTH	compatible with iGO RIDE mobile app (Android & iOS)
MOTOR	250W geared rear hub drive, 36V
TORQUE	up to 45Nm
CONTROLLER	36V high power FOC, Uart
BATTERY	3500mAh SAMSUNG Cell Lithium-Ion 36V / 10.5Ah / 378Wh
RANGE	90km (56mi) *
PAS	Eco/Tour/Sport/Turbo/Boost color coded pedal assist segments
SENSOR	Electronic Dual sided 40 pulse Torque Sensor
CHARGER	36V, 2A, 3 pin, UL Certified
CHARGING TIME	4 to 6 hours
CLASS	MULTI-CLASS SWITCHABLE : Class1 / Class3 capable where permitted **
BIKE WEIGHT	16.7kg (36.8 lbs)
BATTERY WEIGHT	2kg (4.4 lbs)
WEIGHT CAPACITY	125 kg (275 lbs)

Specifications subject to change

\*Actual range may vary depending on Ah of battery rider weight and other riding conditions.

\*\*Electric bike class regulation:

Class 1 : No throttle function, PAS with maximum speed 32km/h (20mph)

Class 2 : Throttle and PAS maximum speed 32km/h (20mph)

Class 3 : Throttle maximum speed 32km/h (20mph), PAS maximum speed 45km/h (28mph)

all classes allow a maximum motor power of 750W(US) or 500W(Canada)

## MAIN TECHNICAL PARAMETERS, SPECIFICATIONS, AND PARTS

ASPIRE VENDOME CE SKU : 100-121-248 (48") | 100-121-254 (54")

PART	DESCRIPTION
FRAME	Hydroformed Aluminum Gravel Road - 48cm (19") or 54cm (21")
COLOR	Matte Graphite
FORK	Hydroformed alloy 700C, quick release
SHIFTERS	SHIMANO ALIVIO 9 Rapidfire Plus
CHAINRINGS	48T
CHAIN	KMC X9
REAR DERAILLEUR	SHIMANO ALIVIO 9-speed
CASSETTE	9-speed 11-32T
HANDLEBAR	Alloy flat bar, 580mm, 31.8mm dia.
STEM	4 bolt, 90mm, 31.8mm clamp dia.
SEAT POST	Alloy 30.4mm with quick release (350mm)
SADDLE	VELO for iGO
BRAKE LEVERS	TEKTRO with reach adjustment
BRAKE CALIPERS	TEKTRO hydraulic disc
ROTOR	160mm
TIRES	700x32C
RIMS	Alloy P23D 700C - black
DISPLAY	2" HD High Brightness IPS Color LCD Display
BLUETOOTH	compatible with iGO RIDE mobile app (Android & iOS)
MOTOR	250W geared rear hub drive, 36V
TORQUE	up to 45Nm
CONTROLLER	36V high power FOC, Uart
BATTERY	3500mAh SAMSUNG Cell Lithium-Ion 36V / 10.5Ah / 378Wh
RANGE	90km (56mi) *
PAS	Eco/Tour/Sport/Turbo/Boost color coded pedal assist segments
SENSOR	Electronic Dual sided 40 pulse Torque Sensor
CHARGER	36V, 2A, 3 pin, UL Certified
CHARGING TIME	4 to 6 hours
CLASS	MULTI-CLASS SWITCHABLE : Class1 / Class3 capable where permitted **
BIKE WEIGHT	16.7kg (36.8 lbs)
BATTERY WEIGHT	2kg (4.4 lbs)
WEIGHT CAPACITY	125 kg (275 lbs)

Specifications subject to change

\*Actual range may vary depending on Ah of battery rider weight and other riding conditions.

\*\*Electric bike class regulation:

Class 1 : No throttle function, PAS with maximum speed 32km/h (20mph)

Class 2 : Throttle and PAS maximum speed 32km/h (20mph)

Class 3 : Throttle maximum speed 32km/h (20mph), PAS maximum speed 45km/h (28mph)

all classes allow a maximum motor power of 750W(US) or 500W(Canada)

## TORQUE TABLE

The following table provides the recommended torque values for components. Ensure all fasteners are tightened carefully and checked regularly. Use of a torque wrench is advised to check values are correct.

Never exceed the recommended torque values.

Some components may have torque values indicated on the part. Always respect the indicated recommended values.

PART	SCREWS / BOLTS	TORQUE VALUE
Rear derailleur	mount bolt	8 - 10 Nm
	cable screw	5 - 7 Nm
Gear lever	mount bolt	5 Nm
Cassette	lockring	40 Nm
Crank	mount bolt	45 - 50 Nm
Pedal	pedal axle	25 - 35 Nm
Saddle	seat post with 1 fitting block	22 Nm
	seat post with 2 fitting blocks	12 Nm
Seat post	clamp	5 - 7 Nm
Stem	faceplate	5 Nm
	steerer	6 - 8 Nm
Grips	clamp screw	2 - 3 Nm
Rack	mount screw to the frame	5 Nm
Fender	mount bolt on the fork	5 Nm
	mount bolt on the rack/frame	5 Nm
Kickstand	bolt	6 - 8 Nm
Brake lever	handlebar mount screw	4 - 5 Nm
Disc brake	rotor screw	4 Nm
Brake caliper	mount bolt	5 - 7 Nm

## SERVICING

Servicing your bike is very important. You can avoid unnecessary damage by servicing your bike regularly.

### General maintenance

- Check tire pressure regularly
- Check brake wear every month and adjust
- Clean and Lubricate the chain occasionally
- If caught in the rain ensure bike and electrical components are wiped dry, remove battery and allow to dry over night
- It is recommended to have your bike evaluated every 3 months by a professional bicycle technician

### Before every ride

- Make sure battery is charged and locked into position
- Check tire pressure
- Check brakes for proper braking
- Always wear an approved bicycle helmet

## CLEANING

Regular cleaning of your electric bike will prolong its life and reduce the appearance of rust and corrosion build up.

REMOVE THE BATTERY BEFORE CLEANING and use brushes and wet sponges to remove dirt. Finish by drying with paper cloths / towel. (Use of a mild soap solution, degreaser, chain lube and a chain cleaning device are recommended for a thorough cleaning.)

When cleaning the electric bike do not submerge parts or let water accumulate by the battery or electrics as prolonged exposure to water may damage these components.

### Note:

Do not use a hose or pressure washer to directly spray the bike. This may result in irreparable water damage and will void your warranty.



## IMPORTANT SAFETY INSTRUCTIONS

ALWAYS WEAR AN APPROVED BICYCLE HELMET WHEN RIDING AN ELECTRIC BIKE

ALWAYS OBEY THE BIKING RULES OF THE ROAD AND PRACTICE PROPER BIKING ETIQUETTE

ALWAYS CHECK LOCAL REGULATIONS REGARDING THE USE OF ELECTRIC BICYCLES

RAINY WEATHER AND WET ROADS REDUCE THE GRIP OF TYRES ON THE GROUND. EXPECT GREATER BRAKING DISTANCES, REDUCE YOUR SPEED AND BRAKE CAREFULLY.

REFLECTORS ARE NOT A SUBSTITUTE FOR REQUIRED LIGHTS. RIDING AT DAWN, AT DUSK, AT NIGHT OR AT OTHER TIMES OF POOR VISIBILITY WITHOUT AN ADEQUATE BICYCLE LIGHTING SYSTEM AND WITHOUT REFLECTORS IS DANGEROUS AND MAY RESULT IN SERIOUS INJURY OR DEATH.

DO NOT TEXT WHILE RIDING

### WARNING

When using this product, basic precautions should always be followed, including :

- Read all the instructions before using the product.
- To reduce the risk of injury, close supervision is necessary when the product is used near children.
- Do not put fingers or hands into the product.
- Leave indoors when charging or not riding.
- Do not use the charger if the flexible power cord or output cable is frayed, has broken insulation, or any other signs of damage.
- Only use a charger supplied or recommended by the manufacturer.
- The battery is intended to be charged when the ambient temperature is between 0°C (32°F) and 30°C (86°F). Never charge the battery when ambient temperatures are outside this range.
- This equipment is not intended to be used at ambient temperatures less than -10°C (14°F) or above ambient temperatures of 50°C (122°F)

### Moving and storage instructions

eBikes can be heavier than non-electric bikes. Ensure any car rack used is certified for use with eBikes and can handle the additional weight when in transport.

As with any bicycle it is encouraged to store your electric bike in a dry temperate environment such as a garage when not in use. Leave indoors when charging or not riding. Prolonged Exposure to UV Rays, Rain and the Elements May Damage the Enclosure Materials, Store Indoors When Not in Use. For long periods of storage the location should protect the bike from extreme heat or cold. It is advised to remove the battery and store inside during extended periods of storage or during extreme temperature.

### Caution for night riding

- Check your bike during the day to make sure that your lighting & reflectors are installed correctly checking for looseness, tightening where needed and clean of any debris.
- Always make sure that the front & rear lighting is operating to its optimal capacity.
- Wear the right gear. It is recommended to wear reflective gear when riding in the dark. Eye protection such as a goggle, or clear protective glasses will keep any night debris from getting into your eyes.
- Ride with a buddy. It is recommended to ride with another person as a back up should an emergency arise.
- Riding conditions at night require a sharper eye. Many obstacles will appear as they are illuminated by the bikes lighting and provide less reaction time so give yourself some extra space between you and your surroundings.

### Caution for wet riding

- Make sure to leave yourself extra stopping time.
- Be sure to wear the appropriate clothing and protective gear. Wet debris can get kicked up to the rider from the mudguards so please be extra cautious.
- When accelerating in wet conditions be careful and make sure to increase speed at a slower pace. Don't lean into corners and take more time to brake.
- Make sure that the appropriate tire pressure is respected. Match the tire pressure to the road & weather conditions. A slightly lower (No less than 5 psi of the recommended pressure written on the sidewall of the tire) tire pressure can provide extra traction in sloppy conditions as more tire surface touches the ground.
- Always keep an eye on where you're heading. Avoid drain covers, grates, oil, and road lines which can become slippery when wet.

### Guide to on/off road riding

On road riding on flat surfaces is very different from Off road terrain.

- Understand your terrain. A bike that is equipped and intended for road riding should not be used for off road riding and vice versa. Only use your product for its intended purpose. Failure to comply could result in injury. We cannot be held responsible for anyone riding their bike which is not equipped for the intended terrain.
- When riding on road conditions make sure to respect the road signage.
- When riding off road, be sure to familiarize yourself with your surroundings. When riding in hills it is important to understand that riding in these conditions can cause you to become unbalanced which requires quick adjustment.
- Failure to understand off road riding characteristics can result in injury.
- Be very careful when riding your bike in snow terrain. A fat tire can be operated with lower tire pressure, so more tire surface is touching the ground. (Only bikes equipped with 26" x 4" or wider tires.) Please see sidewall of tire for proper operating pressure.
- Off road riding requires greater stopping distances compared to on road riding. Please make sure to adjust brakes, cables, derailleur, and all mechanical functions of your bike with your local certified bike tech as described in this user manual. Failure to comply could result in injury.

# WARRANTY

## WARRANTY

iGO Electric warrants to the original retail purchaser (“You”), that the iGO product for which this warranty has been issued is free from defects in material and workmanship for the time detailed below, from the date of original retail purchase. This warranty is not transferable to a subsequent purchaser. iGO’s sole obligation under this warranty is to repair or replace the product, at iGO’s option.

24 months on the Motor drive, Controller, Display, Throttle, lights  
(All electronics excluding the battery) and Frame

18 Months on the battery

Within the first 60 days after purchase iGO will provide the part(s), Labor, & shipping of the parts needed

Beyond 60 days past the purchase date parts are provided but labor & shipping of part(s) is not included

If the product was purchased online, then iGO will arrange the repairs through a local bike shop, and pay the labor & shipping of parts directly to them

If the product was purchased at an authorized dealer, then the customer will have repairs done by the same dealer and warranty will be provided by that dealer as per the warranty conditions

It is the obligation of the customer to present the service products to the service provider as shipping of the product for warranty purposes is not included

A photo of a broken part must be emailed to support@igoelectric.com for authorization

All warranties begin from the date of purchase and are not transferable

Certain warranty conditions may apply, contact your dealer if you have any questions.

## WARRANTY LIMITATIONS

The duration of any implied warranty or condition, of merchantability, fitness for a particular purpose, or otherwise, on this product shall be limited to the duration of the express warranty set forth above. In no event shall iGO be liable for any loss, inconvenience or damage, whether direct, incidental, consequential or otherwise, resulting from a breach of any express or implied warranty or condition, of merchantability, fitness for a particular purpose, or otherwise with respect to this product, except as set forth herein. This warranty gives you specific legal rights, and you may also have other rights, which may vary, from location to location.

This warranty will be interpreted pursuant to the laws of Canada. The original English version/meaning of this warranty controls over all translations and iGO is not responsible for any errors in translation of this warranty or any product instructions. This warranty is not intended to confer any additional legal, jurisdictional, or warranty rights to you other than those set forth herein or required by law. If any portion of this warranty is held to be invalid or unenforceable for any reason, such finding will not invalidate any other provision.

## WARRANTY TERMS

### Article 1: Guarantee

1.1 iGO Electric guarantees that the iGO product you have purchased is free from material and/or workmanship faults.

1.2 If, during the warranty period the product proves to be defective due to faulty materials or workmanship, iGO or an iGO Dealer may charge for labor or parts at its own discretion.

The defective products or parts will be replaced using new or refurbished products or parts.

1.3 This warranty applies within the warranty period, and upon presentation of the original invoice or sales receipt (indicating date of purchase, model name, and dealer) together with the defective product. iGO or iGO Dealers may refuse free warranty service if these documents are submitted incomplete or illegible. This warranty is void if the model name or serial number has been altered, deleted, removed, or made illegible. Battery warranty is void if battery case has been opened.

1.4 The guarantee may be invoked by the first owner of the iGO product only.

1.5 This warranty does not cover transportation costs or risks associated with the transport of your product to and from iGO or your iGO Dealer.

1.6 The warranty is void in accordance with Articles 3.1 and 3.2. Certain restrictions apply in regard to batteries and some electronic parts. Such restrictions are reflected in Article 6.1 and 6.2.

### Article 2: Warranty

2.1 You can only make a warranty claim if you have registered your product at register.igoelectric.com and retained the original proof of purchase. The warranty period begins on the date of purchase.

2.2 iGO bike frames are guaranteed by design and/or material defects for 24 months.

2.3 All electronic parts, such as electronic controller, control panel, motor, throttle, and pedal assist sensor, are subject to a 24-month warranty if properly maintained.

2.4 The battery is subject to a limited 18-month warranty if properly maintained

2.5 On parts that are subject to wear and tear, such as tires, chain, chaining, freewheels, sprockets, cables, and brake pads, there is no warranty on these items, unless there are construction and/or material defects.

### Article 3: Warranty Exclusions

3.1 If the following cases occur, then the warranty is void.

- a. Incorrect and/or improper use of the iGO product.
- b. The iGO product is not maintained in accordance with the guidelines mentioned in the user manual.
- c. Technical repairs have not been performed properly.
- d. Third party components do not match the technical specifications of the bike or were improperly installed.
- e. If proof of ownership, proof that the bike has been checked and adjusted properly prior to the customers receipt of the product, is not present or signed by the seller.

3.2 iGO Electric is free of any liabilities in regard to (parts of) the bike being damaged as a result of:

- a. Improper adjustment of the handlebar, stem, saddle, seat post, gears, brakes, quick release axles of the wheels, and spoke tension.
- b. Not replacing worn out parts such as, brake/derailleur cables, brake pads, tires, chains and sprockets.
- c. Incorrect or insufficient lubrication of moving parts.
- d. Climatic influences such as rust.

### Article 4: Warranty Parts

4.1 During the warranty period, all parts of which iGO has determined of material and/or construction defect, shall be replaced free of charge to the owner. Any costs of (dis)assembly are the responsibility of the owner

4.2 The owner is responsible for any cost of transport for the iGO Product and/or parts to and from iGO unless the product or part is still eligible for warranty.

4.3 If a particular component is eligible for warranty and the original is no longer available, iGO will provide an equivalent alternative.



# NOTES

A large grid of small dots for taking notes.



## REGISTER YOUR eBIKE

### REMEMBER TO REGISTER YOUR eBIKE

To gain full access to all owners benefits, support, and warranty coverage register your bike at :

**[register.igoelectric.com](http://register.igoelectric.com)**

Complete the required information and click SUBMIT at the bottom of the page.

It is advisable to create a customer account on the iGO website. Once created you can add and view all eBikes registered to your account and track communication with iGO support.



Established in 2006

IGOELECTRIC.COM



@igoelectric



Designed in  
Canada